

Presentation

Part Number: WM 336.111

300mm Horizontal Swivel Medical Arm for Laptop, Floor or Ceiling Column Mount

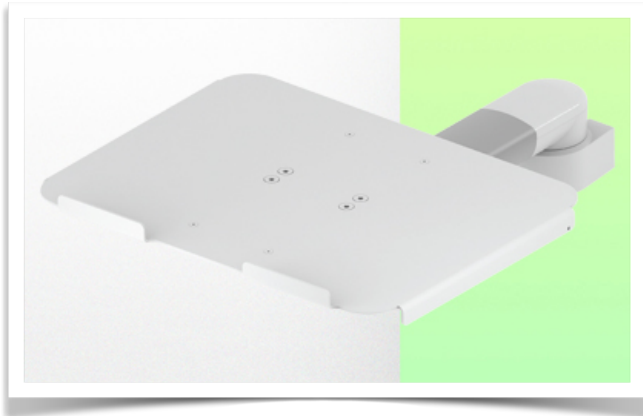

Cette colonne possède deux rails de fixation pour les différents éléments qui y seront fixés. (1 rail à l'avant de la colonne, 1 rail à l'arrière)

This column has two fixing rails for the different elements that will be fixed to it (1 rail at the front of the column, 1 rail at the back)

Deze zuil heeft twee bevestigingsrails voor de verschillende elementen die eraan bevestigd zullen worden (1 rail aan de voorkant van de zuil, 1 rail aan de achterkant)

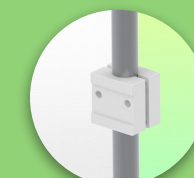

300mm Horizontal Swivel Medical Arm for Laptop, Floor or Ceiling Column Mount

This 300 mm swivel medical arm allows you to fix, orient and adjust your laptop perfectly. It is coated with an anti-microbial agent offering hygiene and cleaning in the smallest details. Its modern design has been specially designed for healthcare environments.

Technical specifications:

- * Integrated cable passage
- * Fixing on floor or ceiling column
- * This 300 mm swivel arm is simply fixed on the column
- * The laptop support delivered in this version has the dimensions of: 360 x 290 mm
- * The weight supported by the arm is 17 kg and 10 kg for the tray
- * Rotation of the Laptop support: 115 ° to the right and left, inclination of 20 °
- * Rotation of the arm: 105 ° to the right and left.
- * Total length 502 mm
- * Color RAL 7024 (Graphite gray) and White
- * All our medical arms are compliant with: CE, ROHS, Medical Grade, MDD 93/42 ECC regulations.
- * Warranty: 5 years

Technical specifications:

Part Number: WM 336.111

300mm Horizontal Swivel Medical Arm for Laptop, Floor or Ceiling Column Mount

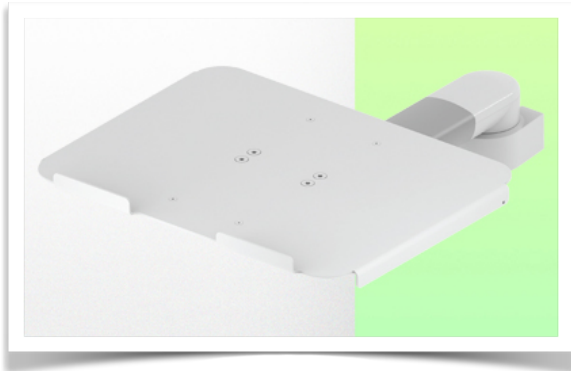

Cette colonne possède deux rails de fixation pour les différents éléments qui y seront fixés. (1 rail à l'avant de la colonne, 1 rail à l'arrière)

This column has two fixing rails for the different elements that will be fixed to it (1 rail at the front of the column, 1 rail at the back)

Deze zuil heeft twee bevestigingsrails voor de verschillende elementen die eraan bevestigd zullen worden (1 rail aan de voorkant van de zuil, 1 rail aan de achterkant)

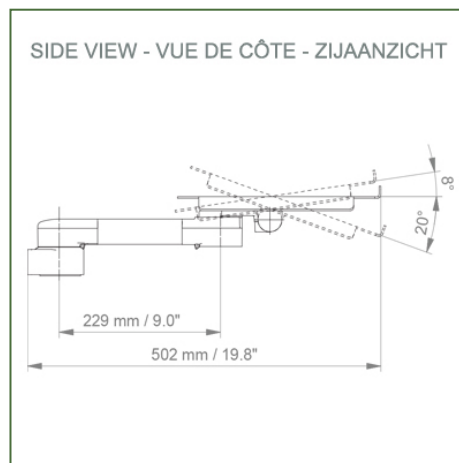
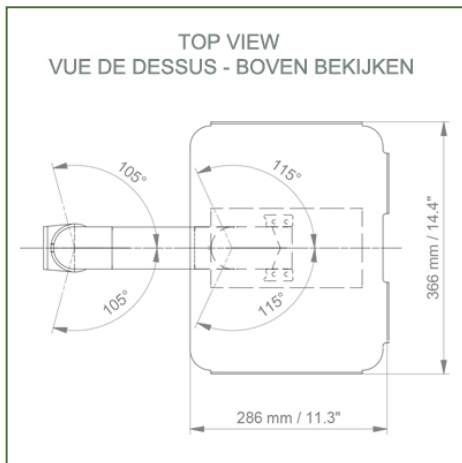
Laptop stand dimensions: 360 x 280 mm

Colour: Decorative parts: RAL 5013 cobalt blue

Aluminium parts: RAL 9016 traffic white

Max. load capacity of the support arm: 17 kg

Load capacity of the tray: 10 kg

Product weight: 2.6 kg

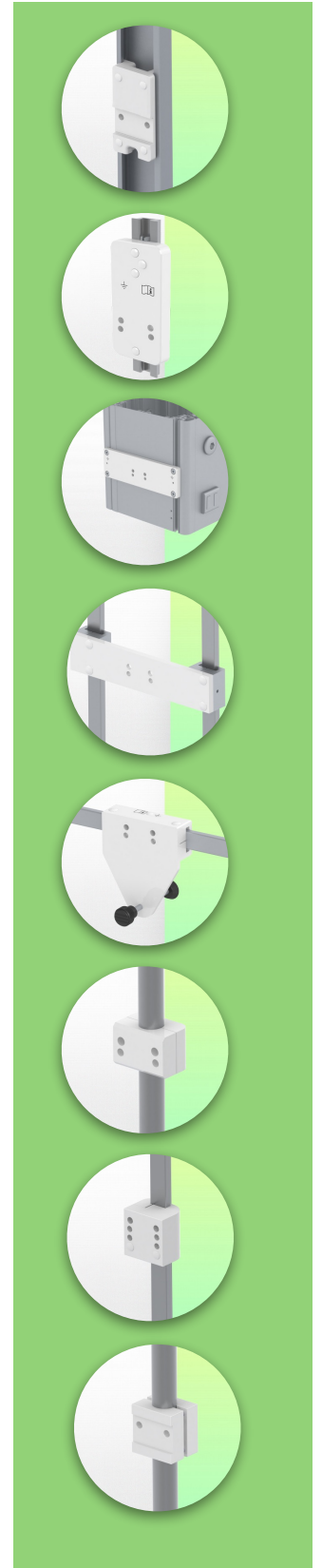

Mounting Information - Column Slide Rail

Part Number: WM 336.111

300mm Horizontal Swivel Medical Arm for Laptop, Floor or Ceiling Column Mount

Floor or ceiling column:

To install this medical arm you must use one of our medical columns. These are available in standard heights of 1500 and 2000 mm. Custom heights are available on request. Slide covers and end caps are supplied with each order.

