

Presentation

Part Number: WM 777.004

Pre-configured lightweight medical trolley for VESA screen

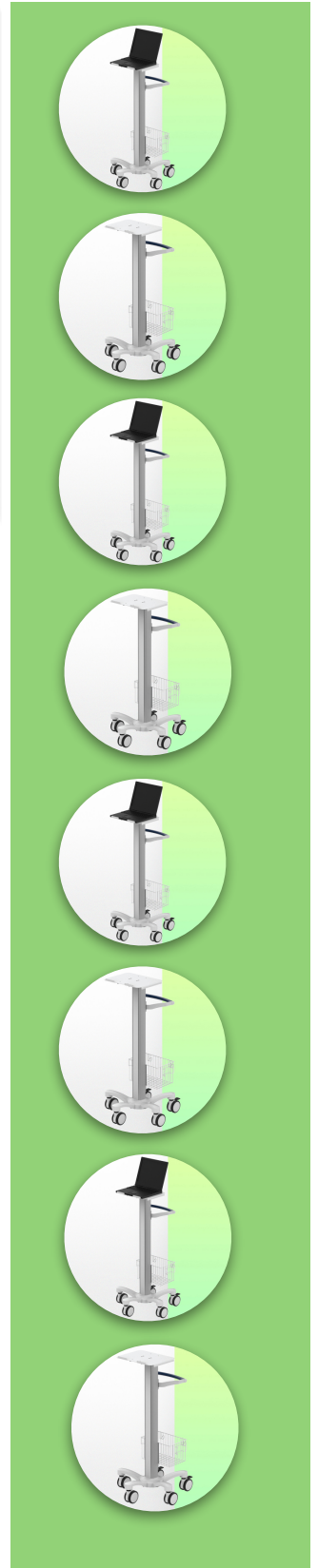
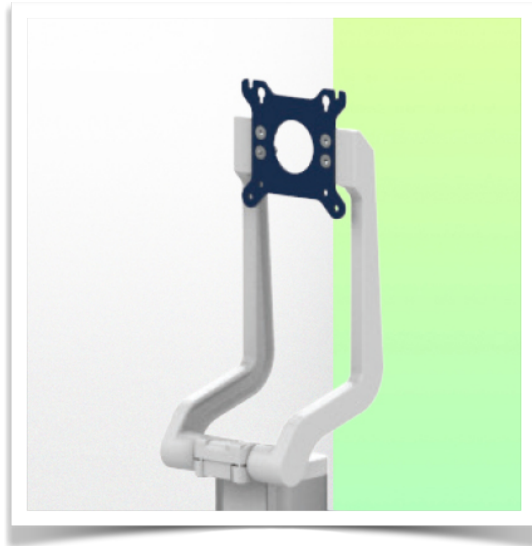

Designed specifically for the medical sector, this pre-configured Vesa Green trolley is the result of close collaboration with nurses, IT specialists and doctors, offering them unrivalled comfort and ergonomics for data entry.

Its lightweight, robust construction in anodised aluminium means that this medical trolley can be moved around intensively without constraint.

Its open architecture provides access points all over the surface of the central column, making it easy to connect accessories.

This medical trolley complies with hospital hygiene standards and can be disinfected down to the smallest detail, including the wheels. There are no rough edges in its design, making it easy to clean and helping to control infections.

Easy to move and hygienic, it's perfect for any patient environment.

Equipped with comfortable, anti-static wheels, this lightweight medical trolley can be manoeuvred effortlessly by nursing staff at the point of care. The wheels (5) make it easy to manoeuvre over bumps and imperfections, and two of the wheels have brakes.

Technical Presentation

Part Number: WM 777.004

Pre-configured lightweight medical trolley for VESA screen

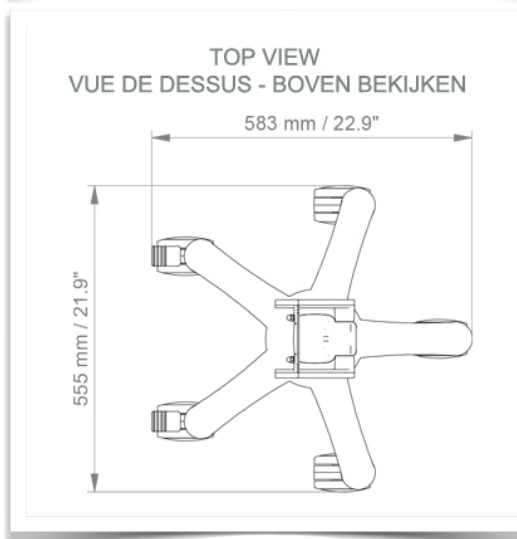
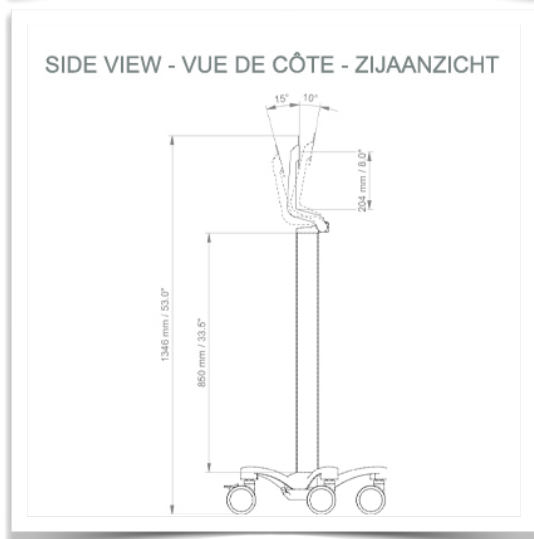
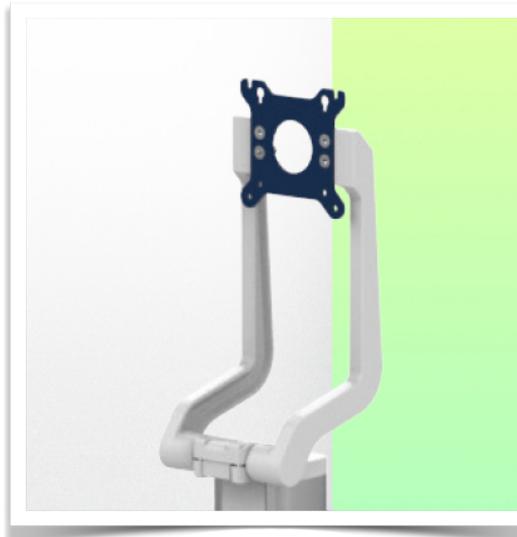

This pre-configuration includes :

- * A Monitor Arm tiltable stand at the head of the column
- * 900 mm high central column
- * A carrying handle
- * Universal service basket (Dimensions: 300 x 200 x 180 mm)
- * Two cable covers
- * 52 cm five-star base
- * Set of five high-precision wheels, two of which have foot brakes
- * CE approved, Hospital Grade
- * Supports up to 7 kg
- * A wide range of accessories completes the station

More details

Part Number: WM 777.004

Pre-configured lightweight medical trolley for VESA screen

