

Presentation

Part Number: WM 250.102MD

595 mm Horizontal Medical Double Arm for monitoring 5" plate adaptation or Quick release, wall mounting on vertical sliding rail. Compatible with Mindray monitoring.

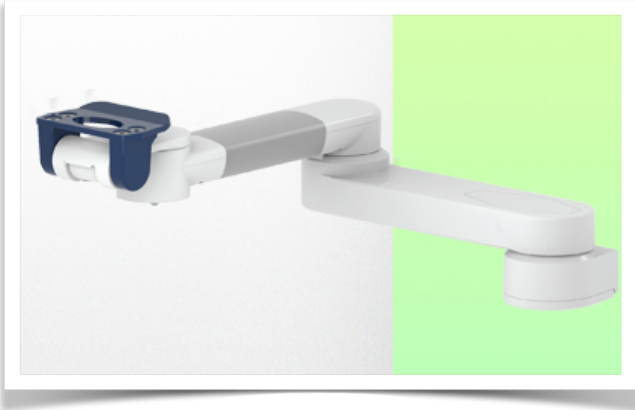

595 mm Horizontal Medical Double Arm for monitoring 5" plate adaptation or Quick release, wall mounting on vertical sliding rail. Compatible with Mindray monitoring.

This 595 mm Horizontal Double Arm allows the monitor to be fixed, oriented and adjusted perfectly. It is coated with an anti-microbial agent to ensure hygiene and cleanliness down to the smallest detail. Its modern design has been specially developed for healthcare environments.

Technical specifications:

- * Integral cable management
 - * For heavy-duty applications
 - * Mounting on optional Vertical Wall Slide Rail, of which several lengths are available (480 mm - 720 mm - 960 mm - 1200 mm). These wall rails can be easily cut to size. All cables also run through the wall rail. (See Option on following pages)
 - * This 595 mm Horizontal Arm simply slides into the wall rail, then adjusts to the required height and locks in place. It has no height adjustment
 - * The head of this arm complies with the mounting standard for Mindray monitors weighing up to 18 Kg.
 - * Monitor tilt: 16° down, 20° up
 - * Monitor rotation: 115° right, 115° left.
 - * Arm rotation: 90° right, 90° left.
 - * Total length: 595 mm Color: RAL 5013 cobalt blue and RAL 9016 traffic white
- Warranty: 5 years

Technical specifications

Part Number: WM 250.102MD

595 mm Horizontal Medical Double Arm for monitoring 5" plate adaptation or Quick release, wall mounting on vertical sliding rail. Compatible with Mindray monitoring.

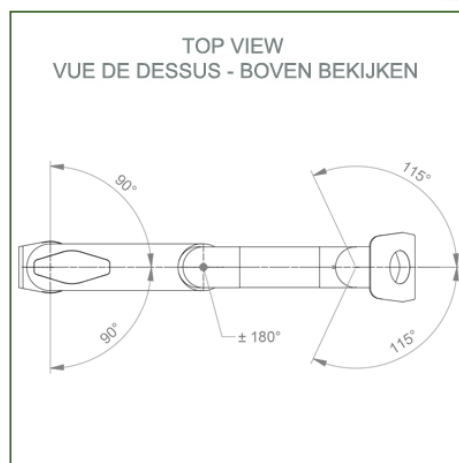
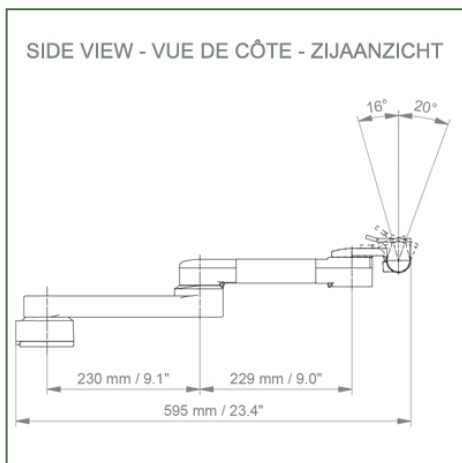
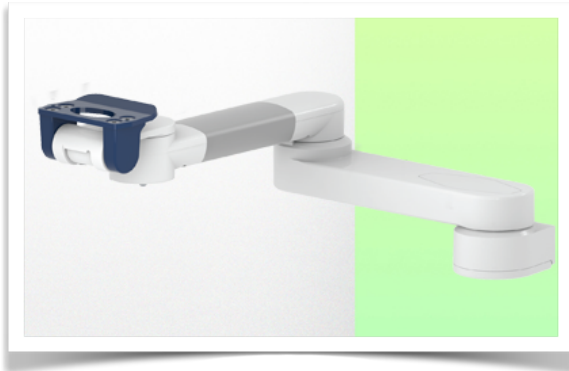

Monitor fitting: 5" Plunge plate or Quick Release
Color: Decorative parts: RAL 5013 cobalt blue
Aluminium parts: RAL 9016 traffic white
Max. load capacity of support arm: 18 kg Monitor
fitting max. load: 18 Kg
Product weight: 3,1 Kg

Product strengths:

Non-height-adjustable arm. Swivel arms and extended swivel arms offer full cable integration and easy cleaning for infection control in all critical care areas of the clinical environment. Our 5-year guarantee ensures reliable, trouble-free and maintenance-free operation. The swivel function at the point of attachment and the tilt and swivel function of the monitor adaptation provide optimum positioning of your unit. The extended swivel arm is a two-part arm with a central pivot point between the two arm sections. All bottom-mounted monitors have the safety feature of a 20° tilt stop.

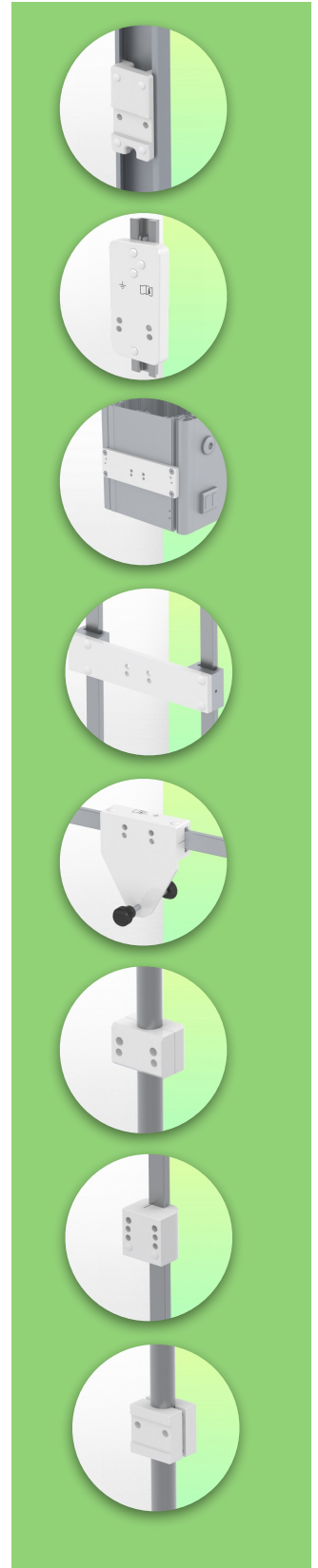

Installation information - Wall-mounted slide rail

Part Number: WM 250.102MD

595 mm Horizontal Medical Double Arm for monitoring 5" plate adaptation or Quick release, wall mounting on vertical sliding rail. Compatible with Mindray monitoring.

Wall-mounted slide rail:

To install this medical arm for monitoring, you must either use an existing rail in your installation or order one of our slide rails. These are available in standard lengths of 480mm, 720mm, 960mm and 1200mm. Custom lengths are available on request. Slide covers and end caps are supplied with every order.

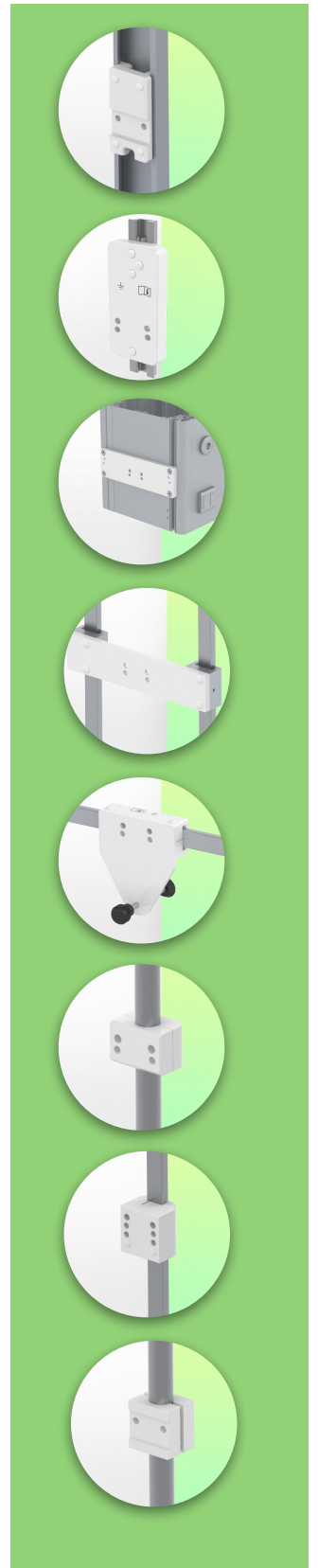
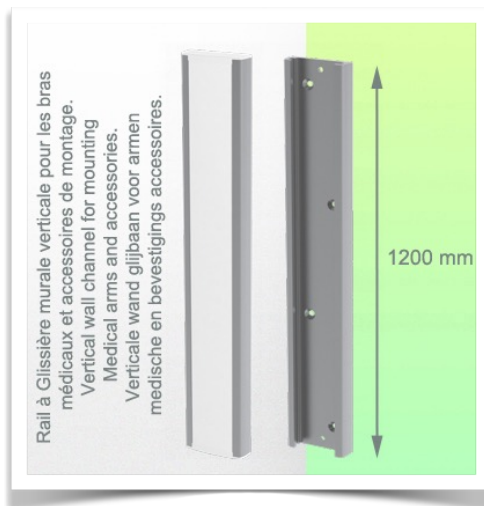
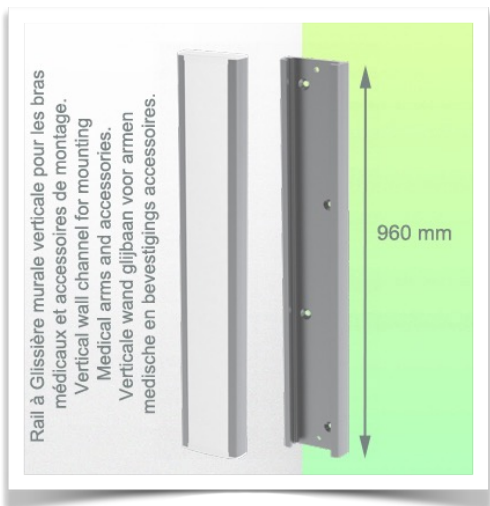
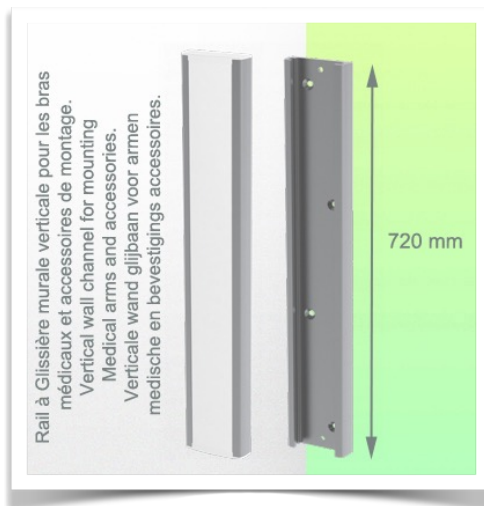
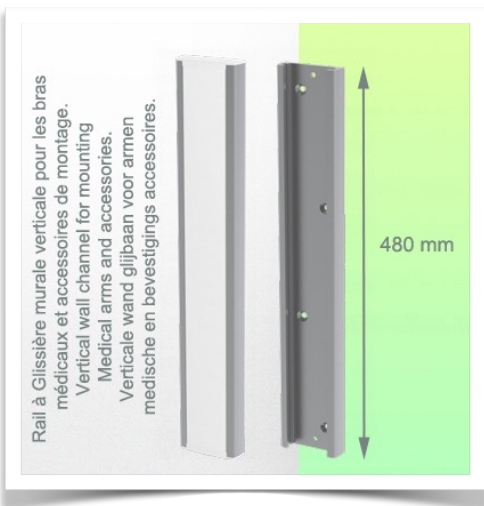

Presentation

Part Number: WM 250.102MD

595 mm Horizontal Medical Double Arm for monitoring 5" plate adaptation or Quick release, wall mounting on vertical sliding rail. Compatible with Mindray monitoring.

Mounting adapter 5" Plunge plate

The 5" plunge plate is suitable for the following Mindray monitors:
BeneVision series: N12, iMEC, uMEC, iPM, ePM, BeneView series: T5, T8, T9 and VS series VS-600, VS-900, VS 8, VS 9.

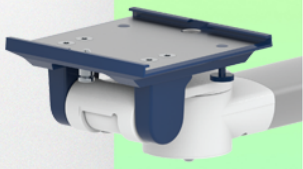

Mounting adapter (quick release)

The monitor adaption is prepared to accept the mounting adapter from Mindray and is suitable for the following Mindray monitors: BeneVision series: N12, iMEC, uMEC, iPM, ePM and BeneView series: T5, T8, T9.

