

Presentation

Part Number: WM 250.105MD

Dual 595 mm Horizontal Medical Arm for monitoring 5" plate adaptor of Quick Release, floor or ceiling column mounting. Mindray monitoring compatible.

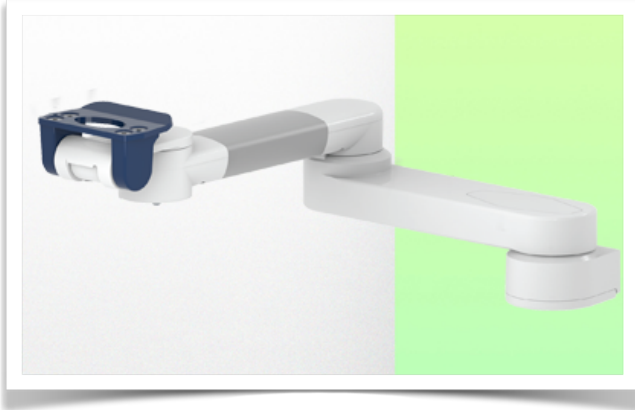

Cette colonne possède deux rails de fixation pour les différents éléments qui y seront fixés. (1 rail à l'avant de la colonne, 1 rail à l'arrière)

This column has two fixing rails for the different elements that will be fixed to it (1 rail at the front of the column, 1 rail at the back)

Deze zuil heeft twee bevestigingsrails voor de verschillende elementen die eraan bevestigd zullen worden (1 rail aan de voorkant van de zuil, 1 rail aan de achterkant)

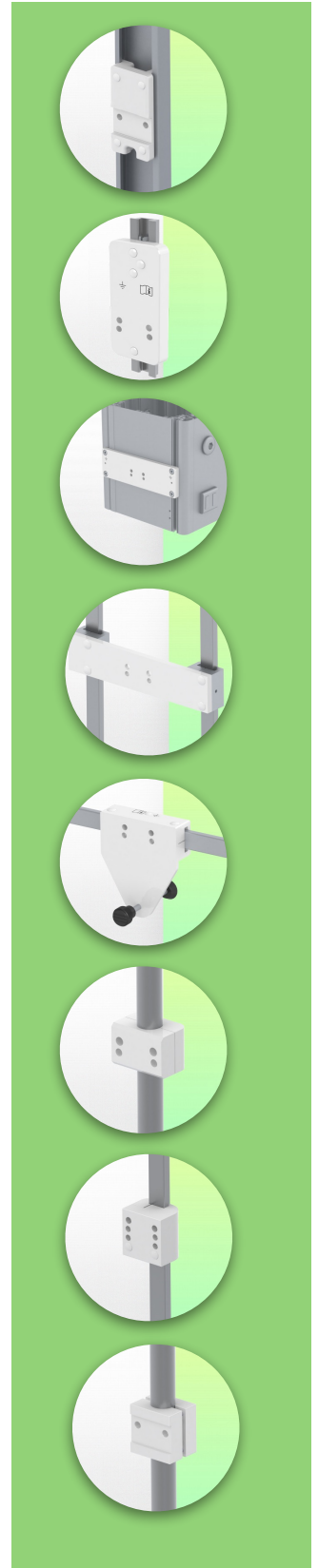

Dual 595 mm Horizontal Medical Arm for monitoring 5" plate adaptor of Quick Release, floor or ceiling column mounting. Mindray monitoring compatible.

This dual 595 mm Horizontal Arm allows the monitor to be perfectly fixed, oriented and adjusted. It is coated with an anti-microbial agent for hygiene and cleaning down to the last detail. Its modern design has been specially developed for healthcare environments.

Technical specifications:

- * Integral cable management * Heavy-duty application
- * Optional floor or ceiling column mounting available in a range of heights (1500 - 2000 mm). These columns can be easily cut to size. All cables also pass through the column (see option on following pages)
- * This 595 mm Double Horizontal Arm simply slides into the column rail, then adjusts to the required height and locks in place. It has no height adjustment
- * The head of this arm complies with the mounting standard for Mindray monitors weighing up to 18 Kg.
- * Monitor tilt: 16° down, 20° up
- * Monitor rotation: 115° right, 115° left.
- * Arm rotation: 90° right, 90° left.
- * Total length: 618 mm
- * Color: RAL 5013 cobalt blue and RAL 9016 traffic white
- * Warranty: 5 years

Technical specifications

Part Number: WM 250.105MD

Dual 595 mm Horizontal Medical Arm for monitoring 5" plate adaptor of Quick Release, floor or ceiling column mounting. Mindray monitoring compatible.

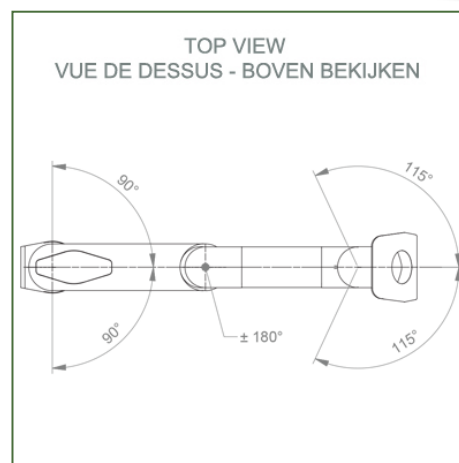
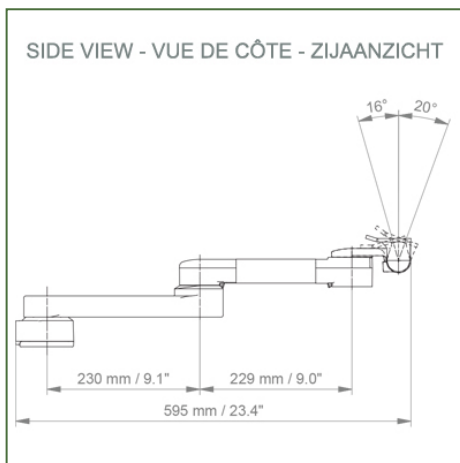
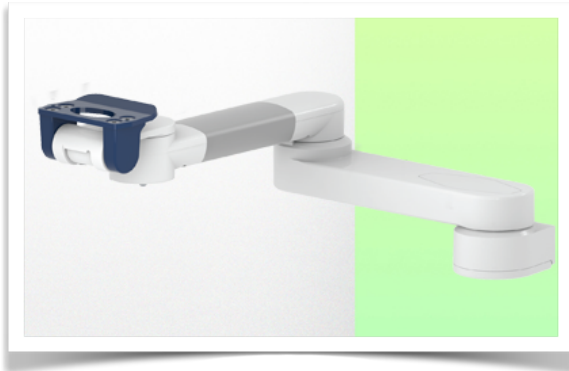

Monitor fitting: 5" Plunge plate of Quick Release

Color: Decorative parts: RAL 5013 cobalt blue

Aluminium parts: RAL 9016 traffic white

Max. load capacity of support arm: 18 kg

Monitor fitting max. load: 18 Kg

Product weight: 3,1 Kg

Product strengths:

Non-height-adjustable arm. Swivel arms and extended swivel arms offer full cable integration and easy cleaning for infection control in all critical care areas of the clinical environment. Our 5-year guarantee ensures reliable, trouble-free and maintenance-free operation. The swivel function at the point of attachment and the tilt and swivel function of the monitor adaptation provide optimum positioning of your unit. The extended swivel arm is a two-part arm with a central pivot point between the two arm sections. All bottom-mounted monitors have the safety feature of a 20° tilt stop.

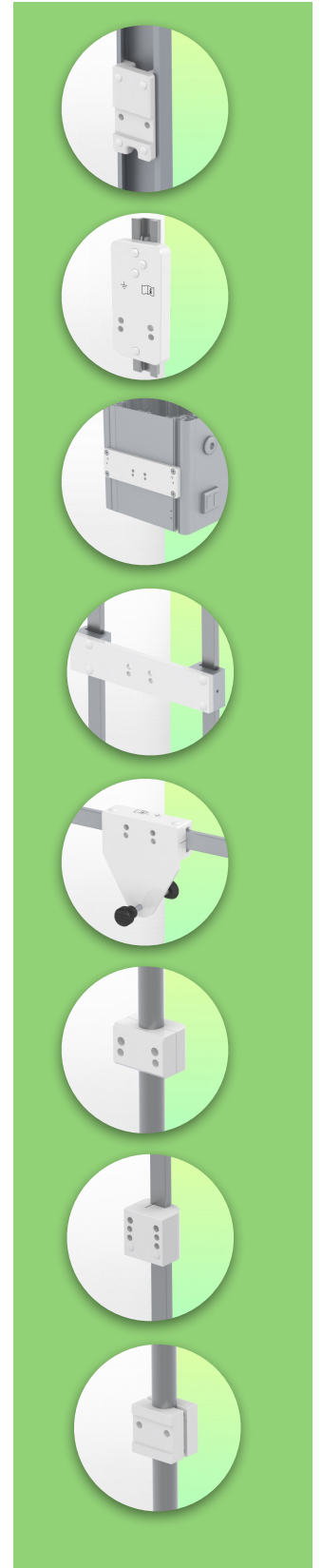

Installation information - Column slide rail

Part Number: WM 250.105MD

Dual 595 mm Horizontal Medical Arm for monitoring 5" plate adaptor of Quick Release, floor or ceiling column mounting. Mindray monitoring compatible.

Floor or ceiling column:

To install this medical arm, you need to use one of our medical columns. These are available in standard heights of 1500 and 2000 mm. Custom heights are available on request. Slide covers and end caps are supplied with every order.

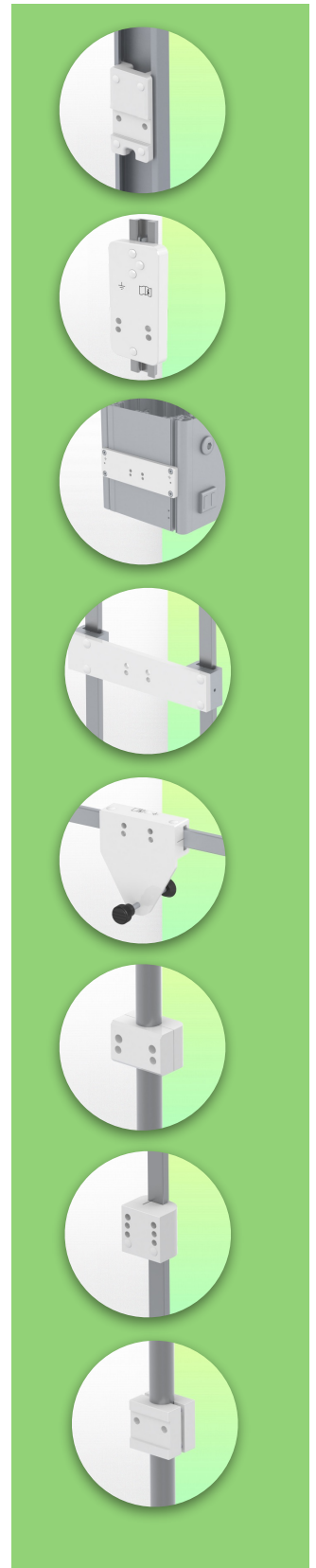
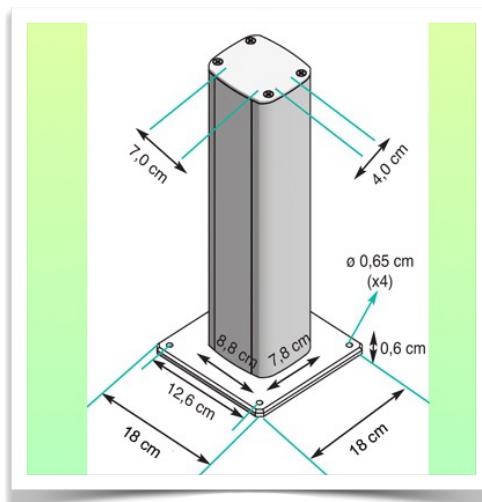
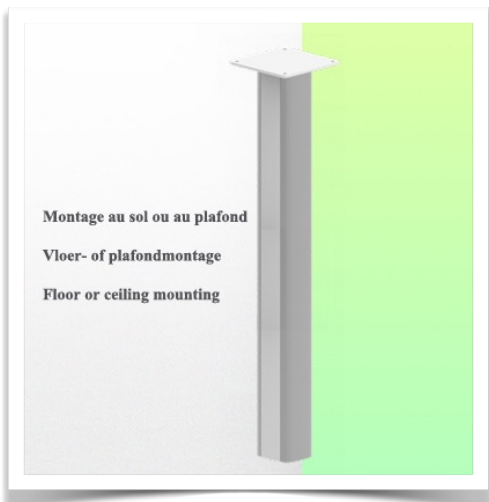
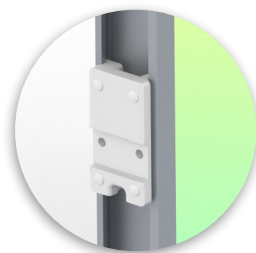
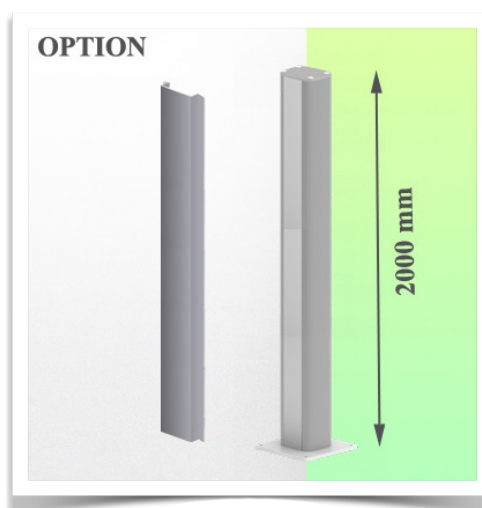
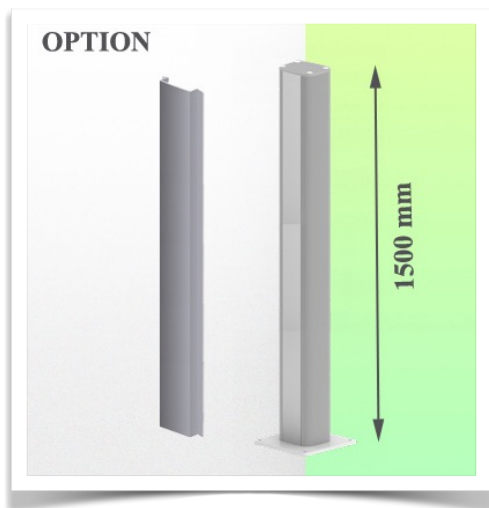

Presentation

Part Number: WM 250.105MD

Dual 595 mm Horizontal Medical Arm for monitoring 5" plate adaptor of Quick Release, floor or ceiling column mounting. Mindray monitoring compatible.

Mounting adapter 5" Plunge plate

The 5" plunge plate is suitable for the following Mindray monitors:
BeneVision series: N12, iMEC, uMEC, iPM, ePM, BeneView series: T5, T8, T9 and VS series VS-600, VS-900, VS 8, VS 9.



Mounting adapter (quick release)

The monitor adaption is prepared to accept the mounting adapter from Mindray and is suitable for the following Mindray monitors: BeneVision series: N12, iMEC, uMEC, iPM, ePM and BeneView series: T5, T8, T9.

