

**Presentation**

**Part Number: WM 260.121**

**363 mm Horizontal Medical Arm for monitoring Philips Intellivue Séries, Mounting on Mindray Medical Supply Device.**

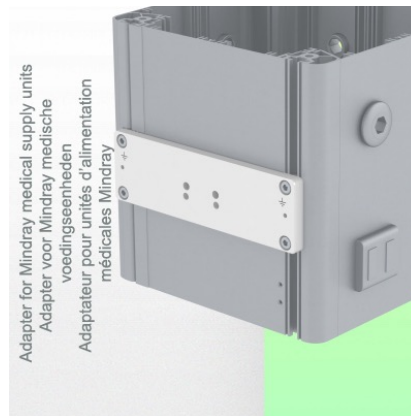
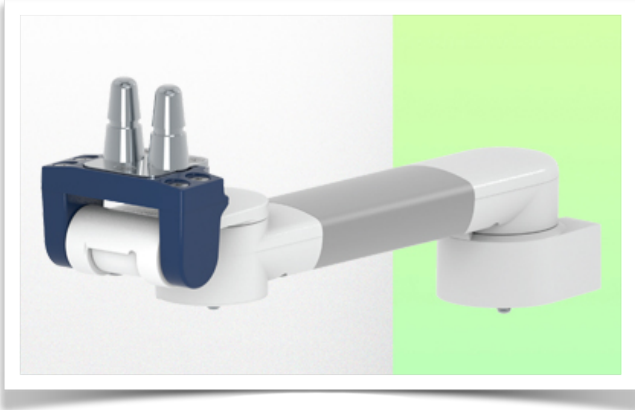

**363 mm Horizontal Medical Arm for monitoring Philips Intellivue Séries, Mounting on Mindray Medical Supply Device.**

This 363 mm Horizontal Arm allows the monitor to be fixed, oriented and adjusted perfectly. It is coated with an anti-microbial agent to ensure hygiene and cleanliness down to the smallest detail. Its modern design has been specially developed for healthcare environments.

**Technical specifications:**

- \* Integrated cable management
- \* Mounting on Mindray Medical Power Supply
- \* This medical arm simply attaches to the rail and then adjusts and pinches with the two clamps. It has no height adjustment.
- \* The head of this arm complies with the mounting standard for Philips Intellivue series monitors weighing up to 18 kg.
- \* Monitor tilt: 20° down and 12° up
- \* Monitor rotation: 115° right, 115° left.
- \* Arm rotation: 105° right, 105° left.
- \* Total length: 363 mm Colour: RAL 5013 cobalt blue and RAL 9016 traffic white
- \* Warranty: 5 years

**Technical specifications**

**Part Number: WM 260.121**

**363 mm Horizontal Medical Arm for monitoring Philips Intellivue Séries, Mounting on Mindray Medical Supply Device.**

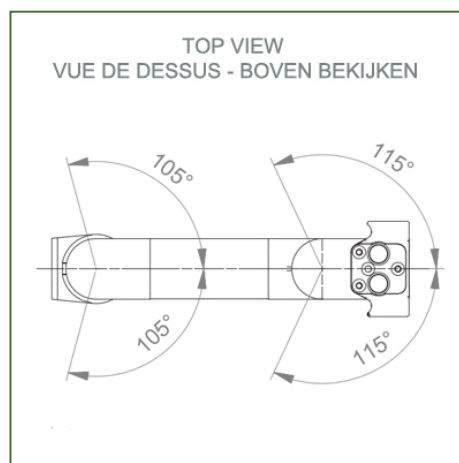
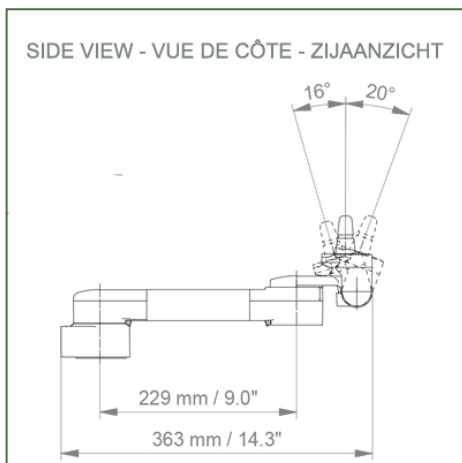
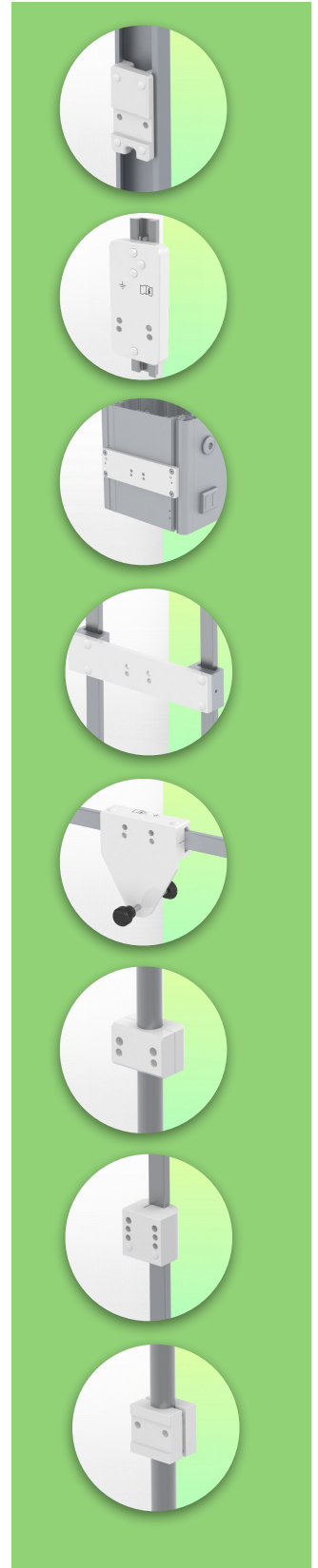
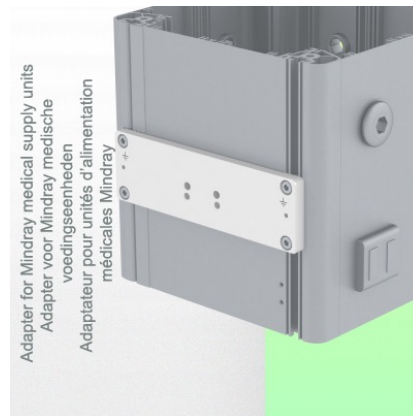
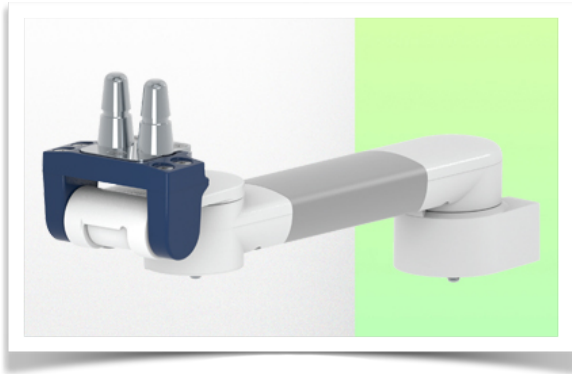

- Monitor fitting:** Philips Intellivue Series
- Colour:** Decorative parts: RAL 5013 cobalt blue
- Aluminium parts:** RAL 9016 traffic white
- Max. load capacity of support arm:** 18 kg
- Monitor fitting max. load:** 18 Kg
- Product weight:** 1,9 Kg

**Product strengths:**

Non-height-adjustable arm. Swivel arms and extended swivel arms offer full cable integration and easy cleaning for infection control in all critical care areas of the clinical environment. Our 5-year guarantee ensures reliable, trouble-free and maintenance-free operation. The swivel function at the point of attachment and the tilt and swivel function of the monitor adaptation provide optimum positioning of your unit. The extended swivel arm is a two-part arm with a central pivot point between the two arm sections. All bottom-mounted monitors have the safety feature of a 20° tilt stop.

**Mounting information - Adapter Mindray**

Part Number: WM 260.121

**363 mm Horizontal Medical Arm for monitoring Philips Intellivue Séries, Mounting on Mindray Medical Supply Device.**

**Adapter Mindray:**

Mounting on Mindray Medical Supply Device

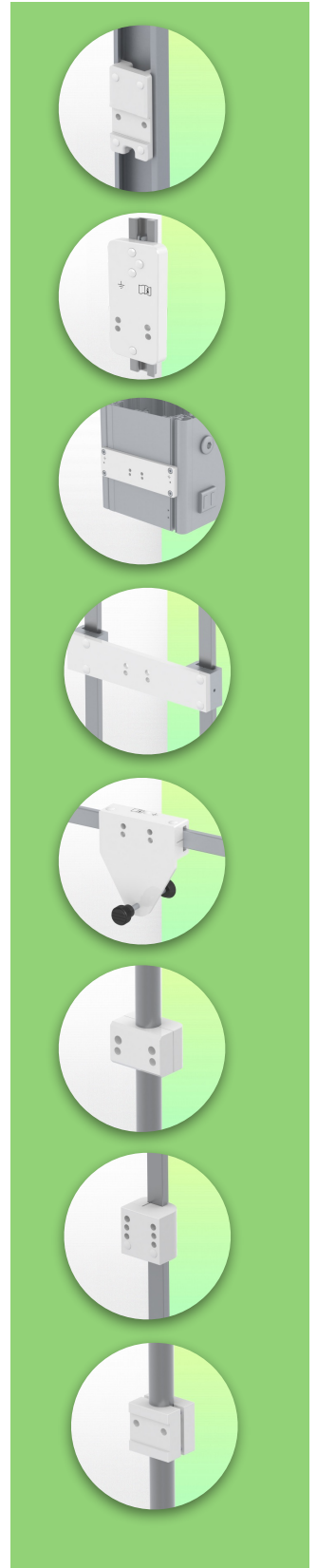
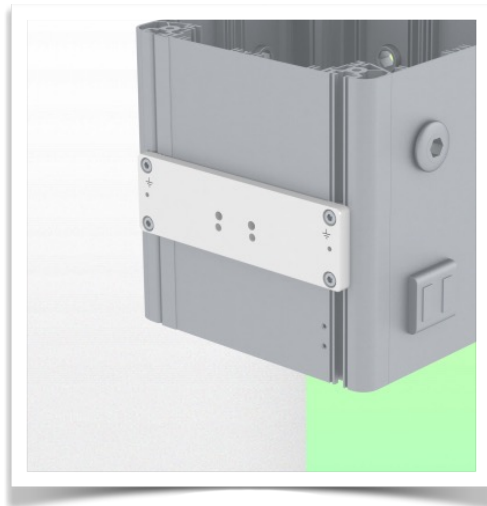
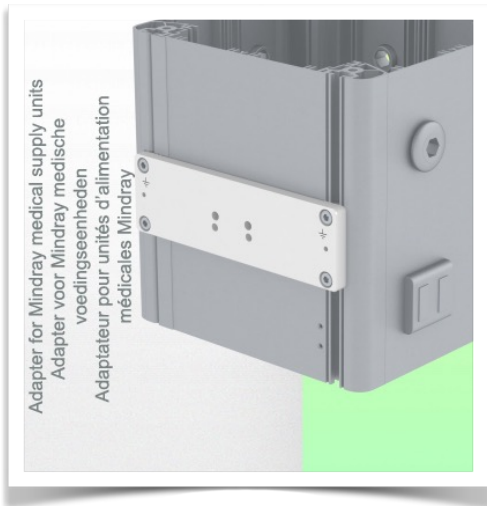

**Presentation**

**Part Number: WM 260.121**

**363 mm Horizontal Medical Arm for monitoring Philips Intellivue Séries, Mounting on Mindray Medical Supply Device.**

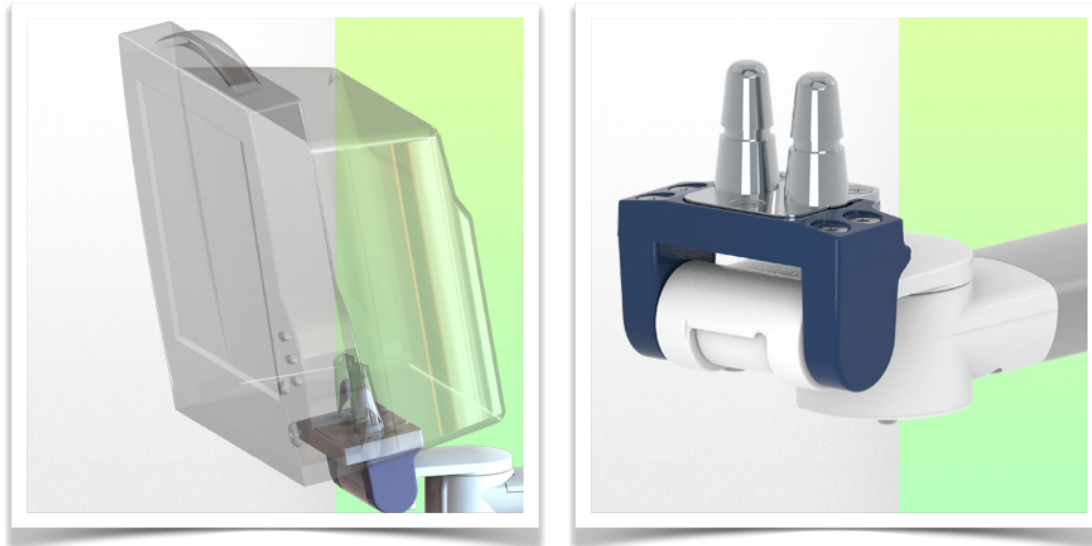

**Adaptation monitoring Philips Intellivue series**

All our medical arms can be fitted with this adaptation, some illustrations of which can be found here.

