

Presentation

Part Number: WM 260.123

Medical Horizontal swivel arm 2 x 300 mm for monitoring Philips Intellivue Séries (Heavy Duty applications up to 18 Kg), Mounting on Mindray Medical Power Supply Device.

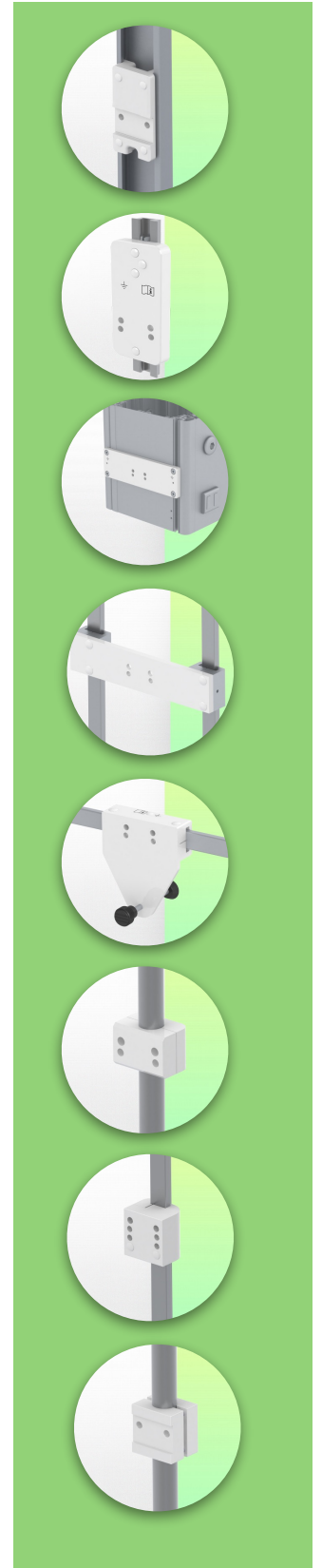
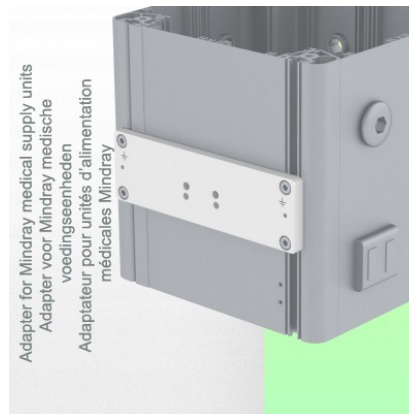
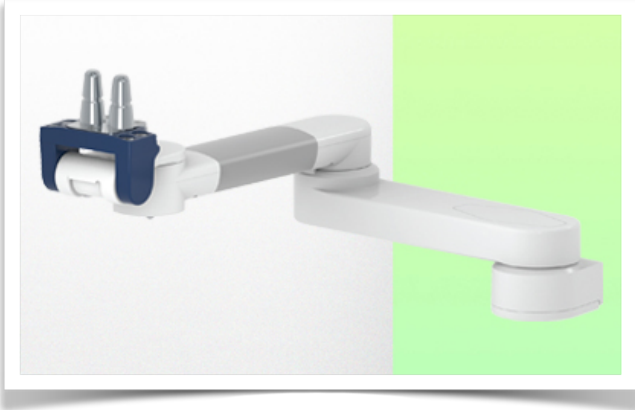

Medical Horizontal swivel arm 2 x 300 mm for monitoring Philips Intellivue Séries (Heavy Duty applications up to 18 Kg), Mounting on Mindray Medical Power Supply Device.

This 594 mm dual Horizontal Arm allows you to fix, orient and adjust the monitor perfectly. It is covered with an anti-microbial agent offering hygiene and cleaning in every detail. Its modern design has been specially designed for healthcare environments.

Technical characteristics:

- * Built-in cable passage
- * For Heavy Duty Application
- * Mounting on Mindray Medical Power Supply
- * This medical arm simply attaches to the rail and then adjusts and pinches with the two clamps. It has no height adjustment.
- * The head of this arm complies with the Philips Intellivue Series monitor mounting standard, which does not exceed 18 Kg.
- * Monitor tilt: 20° down and 12° up
- * Monitor rotation: 115° right, 115° left.
- * Arm rotation: 90° right, 90° left.
- * Total length 594 mm
- * Color RAL 5013 cobalt blue and RAL 9016 traffic white
- * Warranty: 5 years

Technical specifications

Part Number: WM 260.123

Medical Horizontal swivel arm 2 x 300 mm for monitoring Philips Intellivue Séries (Heavy Duty applications up to 18 Kg), Mounting on Mindray Medical Power Supply Device.

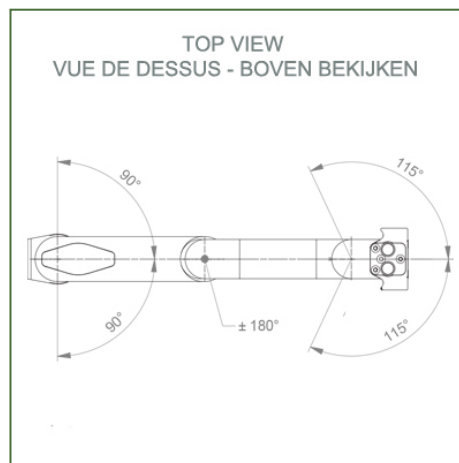
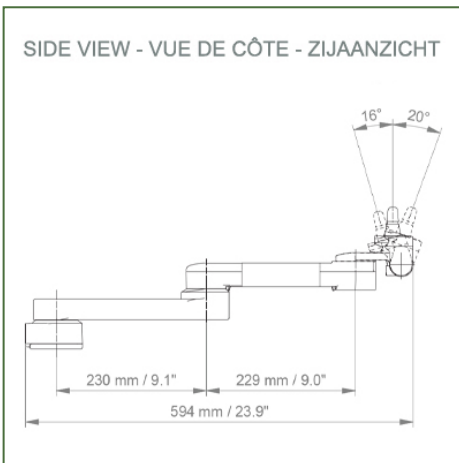
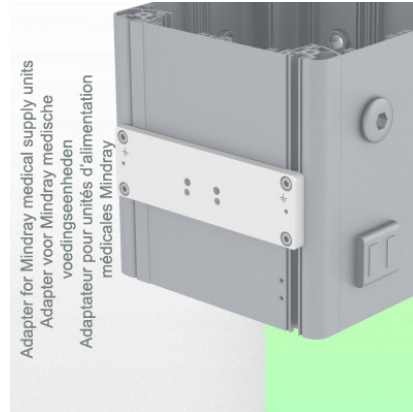
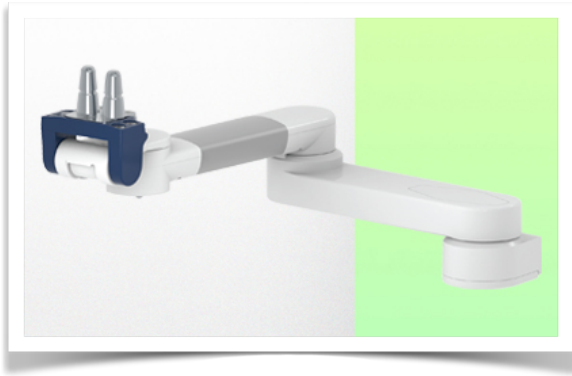

Monitor adaptation: Philips Intellivue series
Color: Decorative parts: RAL 5013 cobalt blue
Aluminum parts: RAL 9016 traffic white
Max load capacity, support arm: 18 kg
Max load monitor adaptation: 18 kg
Product weight: 3.1 kg

Product highlights:

Arm not adjustable in height. The pivoting arms and extended pivoting arms provide complete cable integration and easy cleaning for infection control in all critical care areas of the clinical environment. Our 5-year warranty guarantees reliable, trouble-free and maintenance-free operation. The swivel function at the attachment point as well as the tilt and swivel function of the monitor adaptation provide optimal positioning of your device. The extended swing arm is a two-part arm with a central pivot point between the two arm sections. All monitors mounted at the bottom have the safety function of a 20° tilt stop.



Mounting information - Adapter

Part Number: WM 260.123

Medical Horizontal swivel arm 2 x 300 mm for monitoring Philips Intellivue Séries (Heavy Duty applications up to 18 Kg), Mounting on Mindray Medical Power Supply Device.

Adapter Mindray:

Mounting on Mindray Medical Supply Device

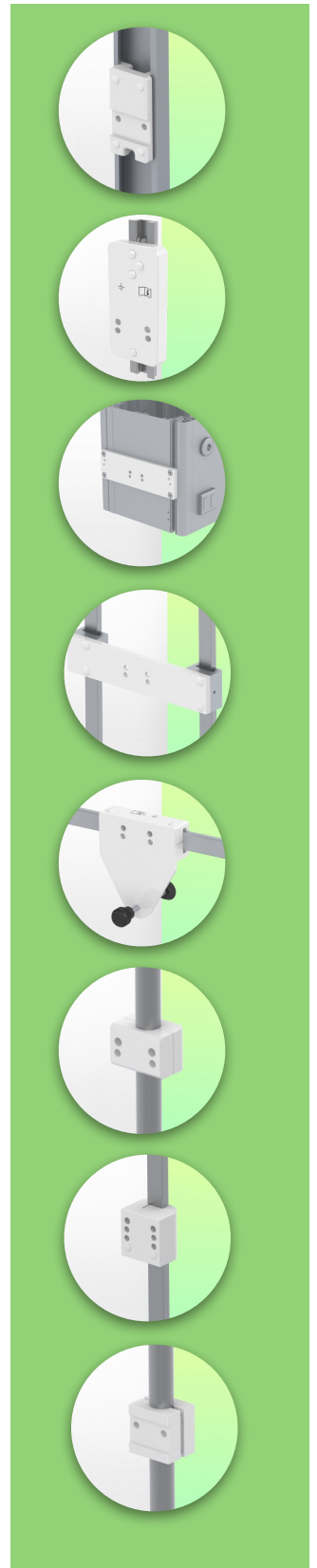
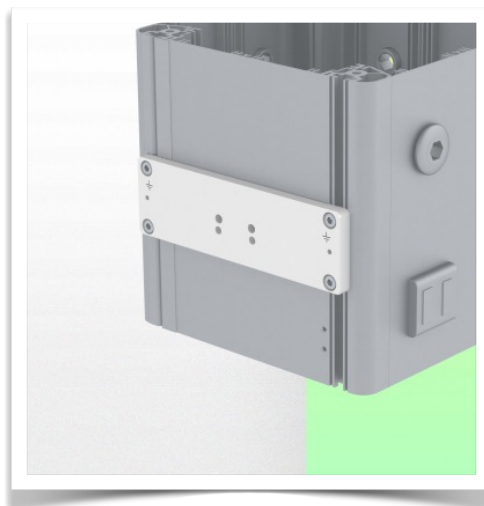

Presentation

Part Number: WM 260.123

Medical Horizontal swivel arm 2 x 300 mm for monitoring Philips Intellivue Séries (Heavy Duty applications up to 18 Kg), Mounting on Mindray Medical Power Supply Device.



Adaptation monitoring Philips Intellivue series

All our medical arms can be fitted with this adaptation, some illustrations of which can be found here.

