



WorkiMed[®]
WORK PLACE TECHNOLOGY

ErgonoFlex[®]

INSTRUCTION MANUAL



WORKIMED WM 444.100

WORKIMED WM 444.101



Medical flat screen mount



Medical Display Halterung



Supporto medico per schermo piatto



Suporte para ecrã médico plano



Sairaala näyttöjen teline



Medisinske flatskjermfeste



Medische flatscreen steun



Support médical pour écran plat



Soporte para pantalla medica plana



Medicinske fladskærmbeslag



Fäste för medicinska platta skärmar



Flat screen floor stand



INSTRUCTION MANUAL

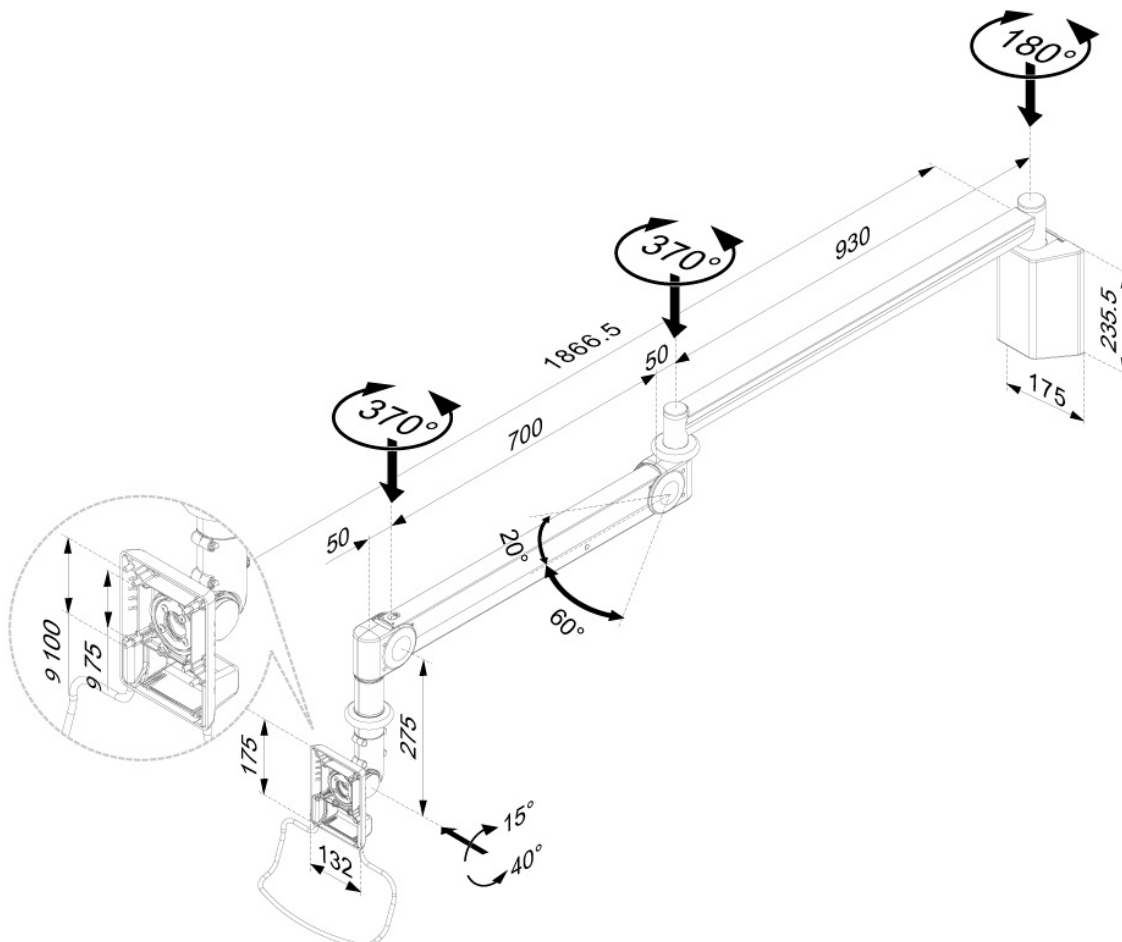

INSTRUCTION MANUAL

Before starting Assembly

- Please spend some time reading this installation guide then follow the simple step by step guide to assembly.
- Some panels are viewed differently from the exploded drawing below, this is for extra clarity.
- Do not discard any of the packaging until you have checked all the parts and the pack of fittings.
- If you are missing any of the parts, contact supplier where you purchased.

Check list -----	02
Arm Operation-----	03
For positioning the HA products-----	04
The serviceable range of arm-----	05
Wall Hanger Assemble-----	06
Part introductio-----	10
Remove cable covers -----	11
Insert cables through arm-----	13
LCD Monitor Assembly-----	15
Adjustment For Loading-----	17
Replace the arm covers-----	18
Adjustment For Loading-----	20
Adjusting Universal Joint Tension-----	21
Safety Notes-----	22













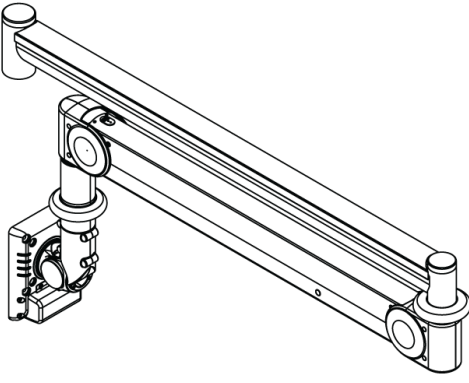
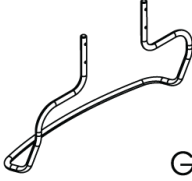

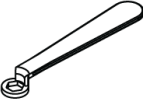
THE INSTALLATION SHOULD BE PERFORMED BY A QUALIFIED TECHNICIAN AND SHOULD MEET THE REQUIREMENTS OF LOCAL REGULATIONS.

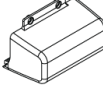

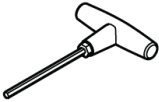

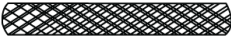
Note: Only if necessary, all fixing material can be replaced by the installer at their own discretion depending on the requirements of the wall composition; WorkiWay will not be held responsible if fixing material supplied by third parties fails to sufficiently secure the wall bracket to the wall.

In accordance with our policy of constant improvement, we reserve the right to alter specifications of products shown.

INSTRUCTION MANUAL

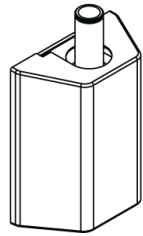
Check list

01		Arm X1	02		Grab Handle X1
03		(M4X12) Screw X4	09		Wrench X2
04		(M6X30) Screw X4	10		VESA cable cover-B X1
05		(M4X25) Screw X4	11		"T" Allen key X1
06		spacer sleeve X4	12		Cable Wrapper X1
07		(2.5mm) Allen key X1	13		Cable tie X4
08		(4mm) Allen key X1			

14		X1	15		X4
			16		X2
			17		X1



INSTRUCTION MANUAL

Arm Operation

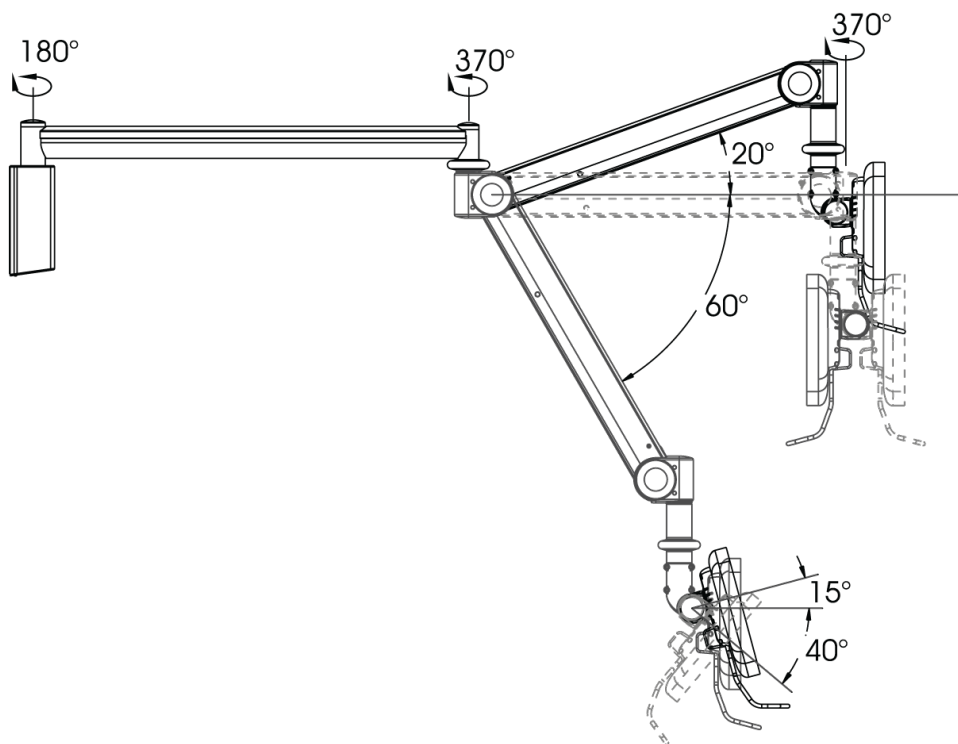

INSTRUCTION MANUAL

For example for positioning the WM Products.

Right view

Unit:mm

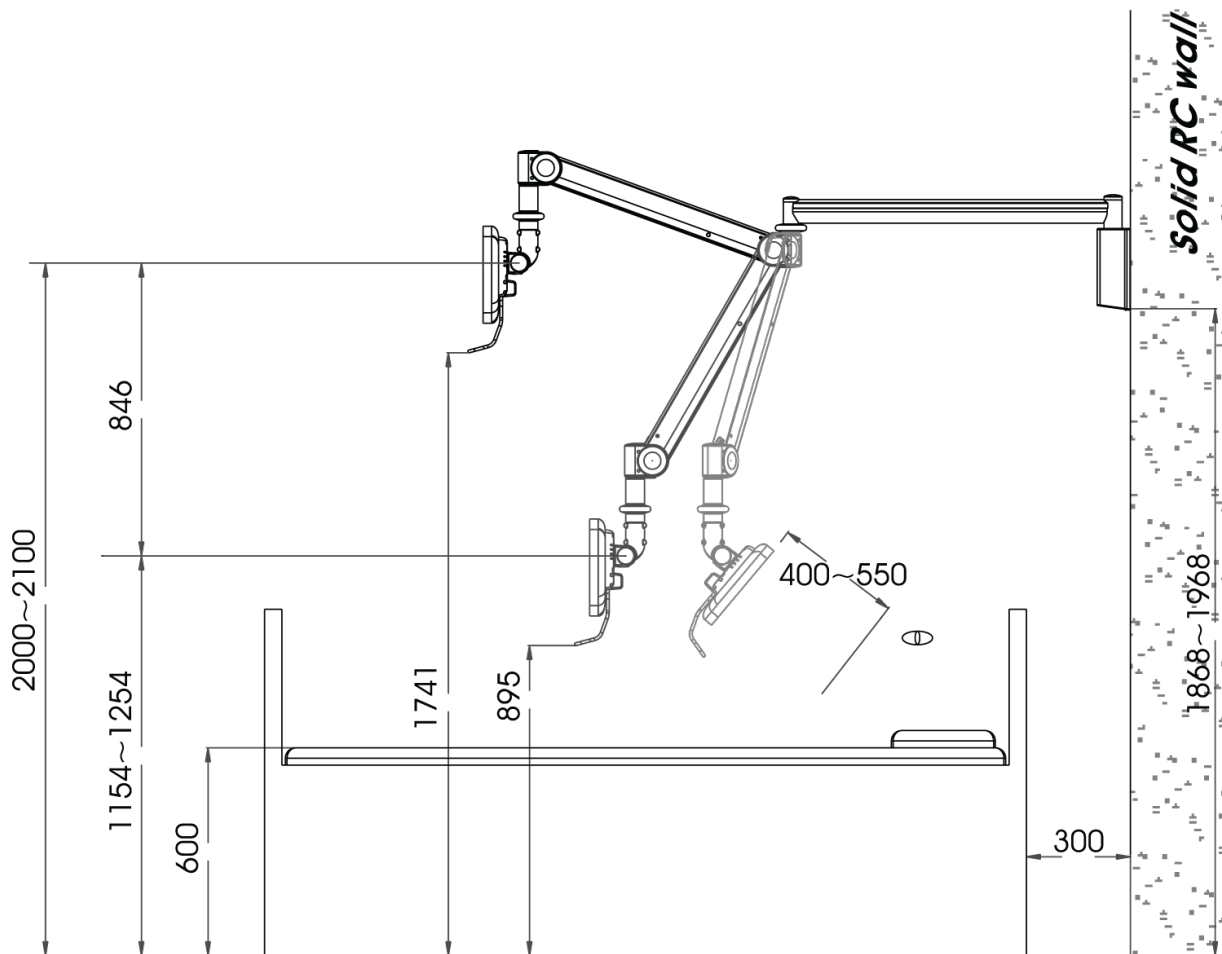



INSTRUCTION MANUAL

The serviceable range of arm at +20 degree Top view

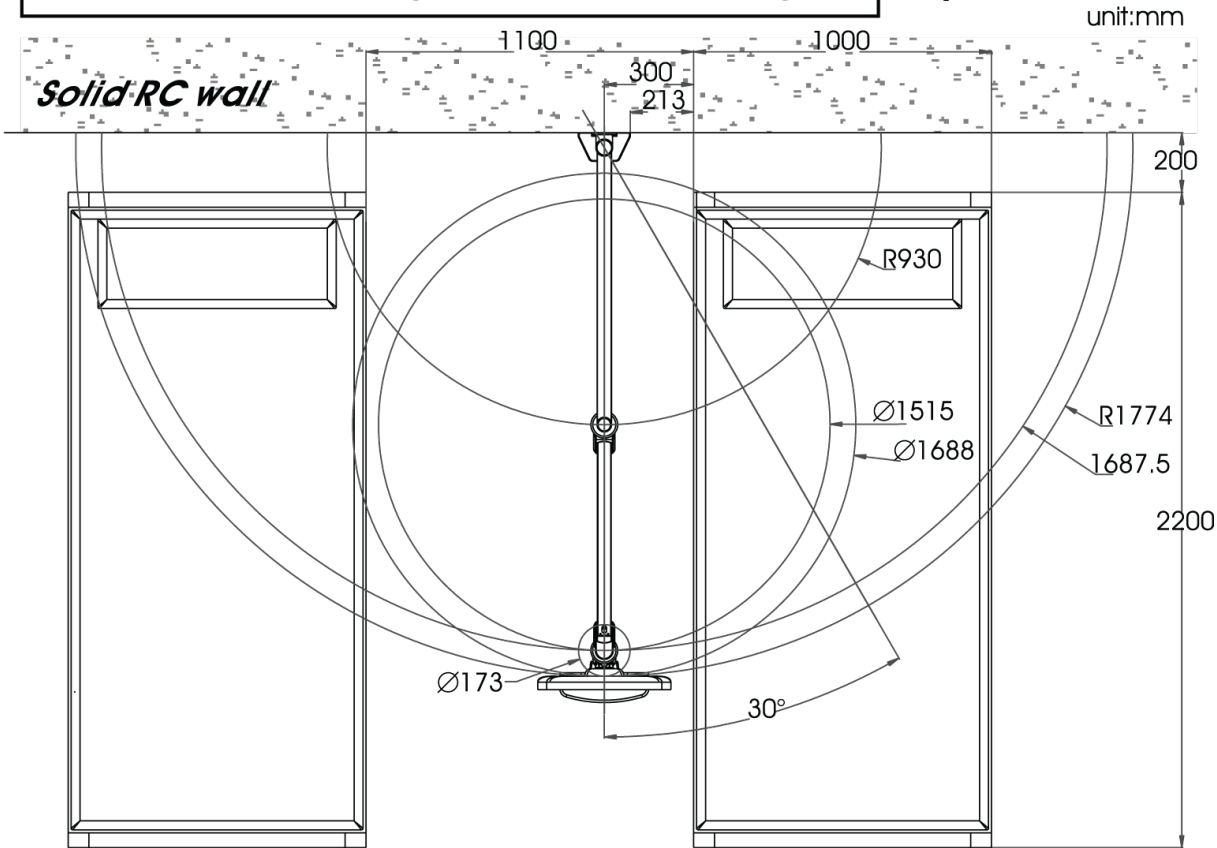

The serviceable range of the arm at -60 degree Top view

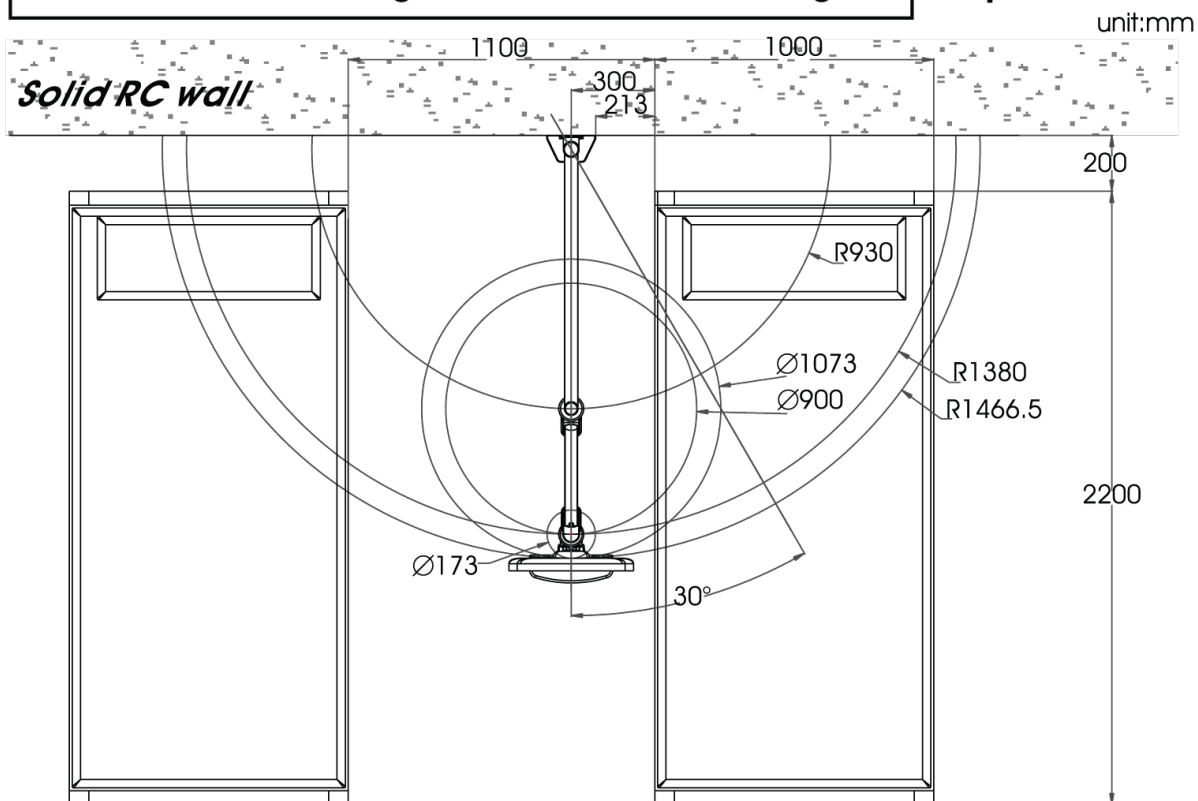

INSTRUCTION MANUAL

Wall Hanger Assemble:

Note:

●Use level gauge or protractor to help the wall mount installation.

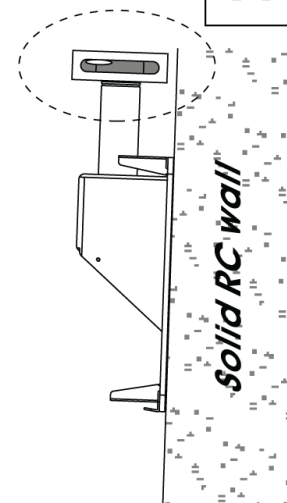
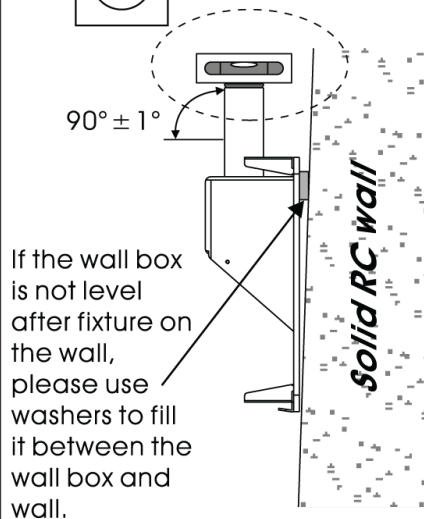
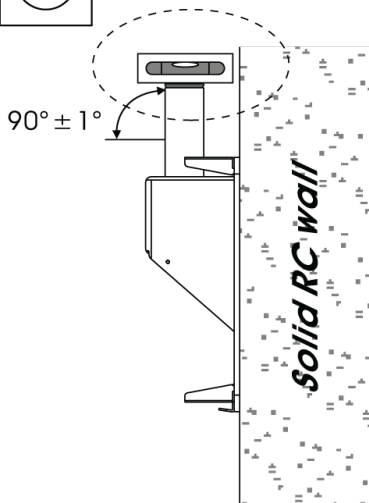
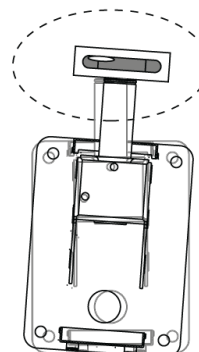
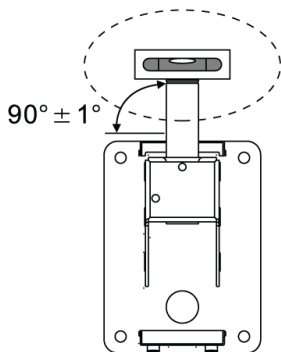
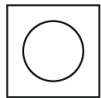
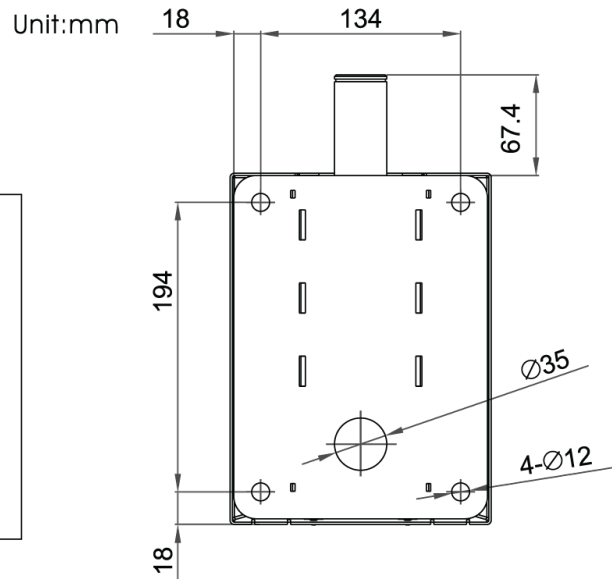
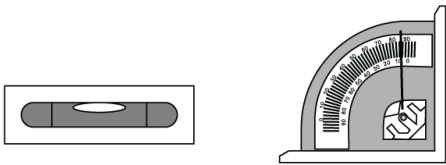

INSTRUCTION MANUAL

Wall Hanger Assemble:

1.1

1. Make sure the substantial wall before assembling.
2. Please take screwdriver to loosen the wall hanger then take out the cover of wall hanger. Do not discard the cover of wall hanger after take it out!
3. Put the wall hanger on the exact place & height that you want and have 4 marks on the wall.
4. Install the wall hanger on the wall with 4 expansion bolts.
Recommended drill bit size: diameter $\varnothing 12.7\text{mm}$ / depth $60 \pm \frac{2}{0}$ mm.

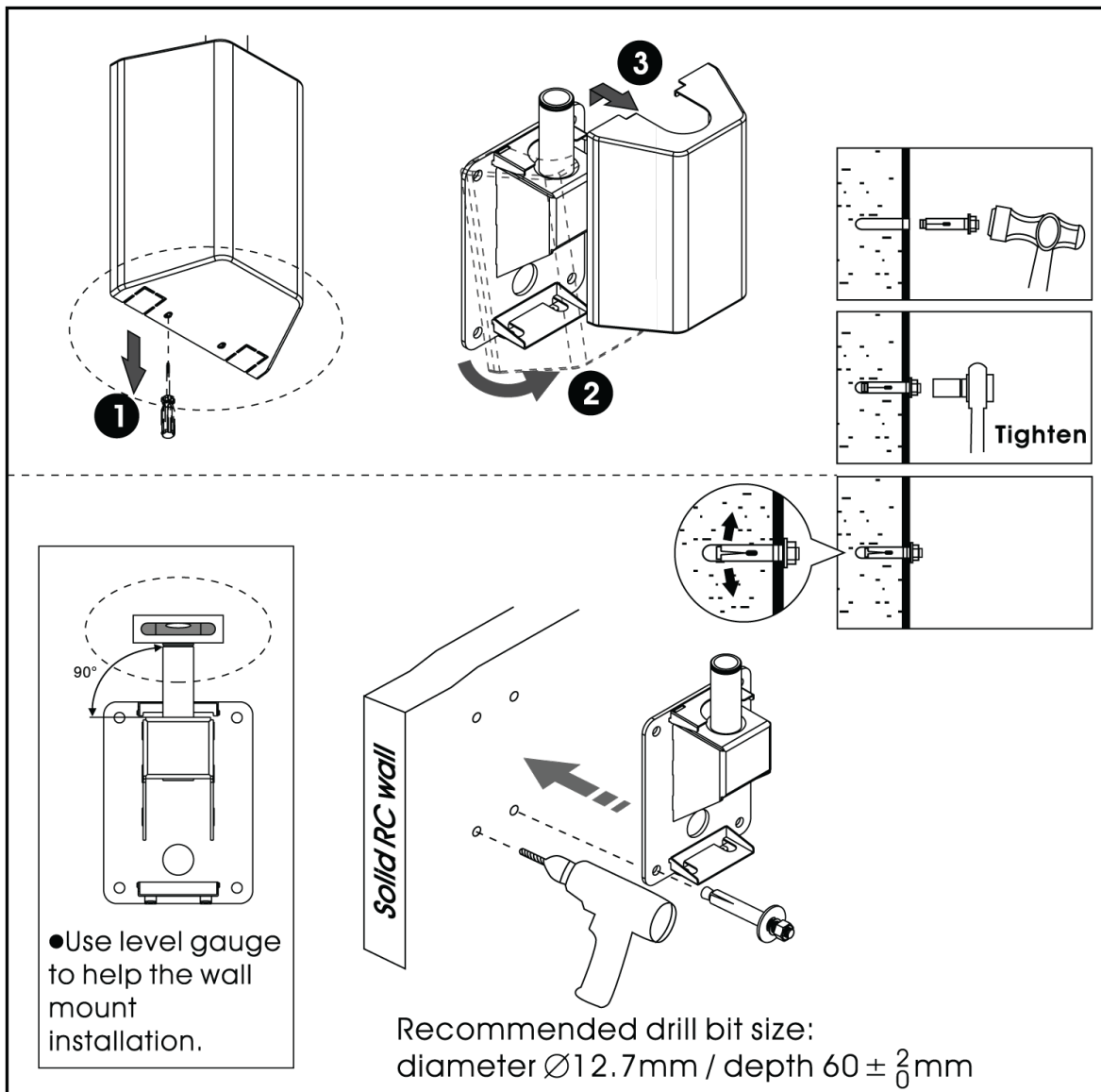



INSTRUCTION MANUAL

Only keep the drawing on the assembly guide

1.2

1. Place the bearings onto the spindle.
2. Place the arm onto the spindle.
3. Manage the cables well, and then make sure that C clip is fitted into groove of spindle securely so the fixed section of arm cannot be pulled out from the wall mount while adjusting the arm.
4. Put the rotating cover-L on arm.

16		X2
17		X1

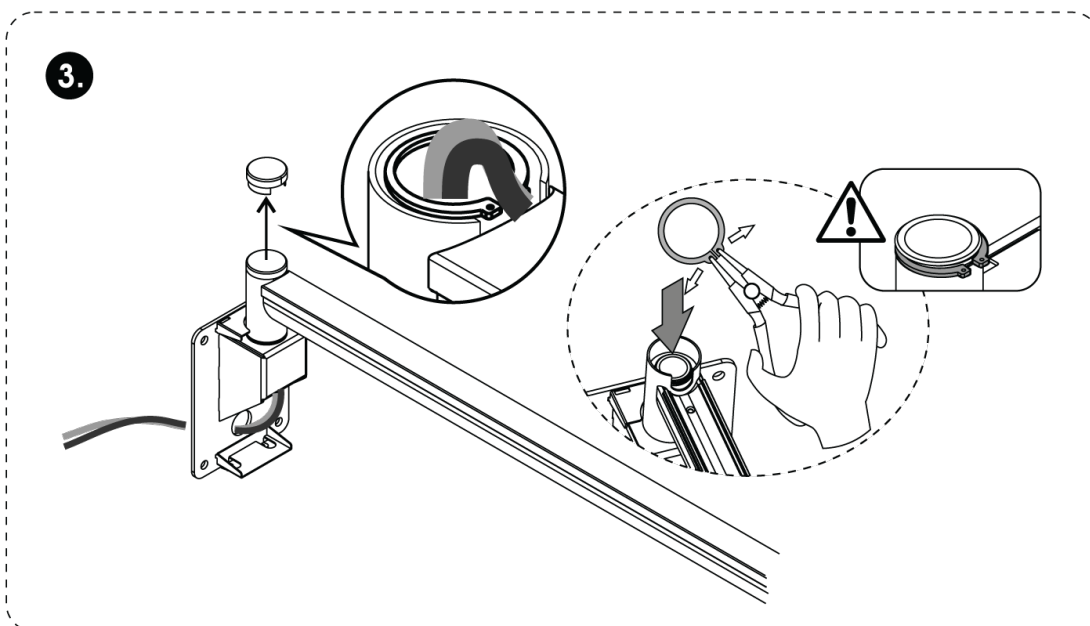
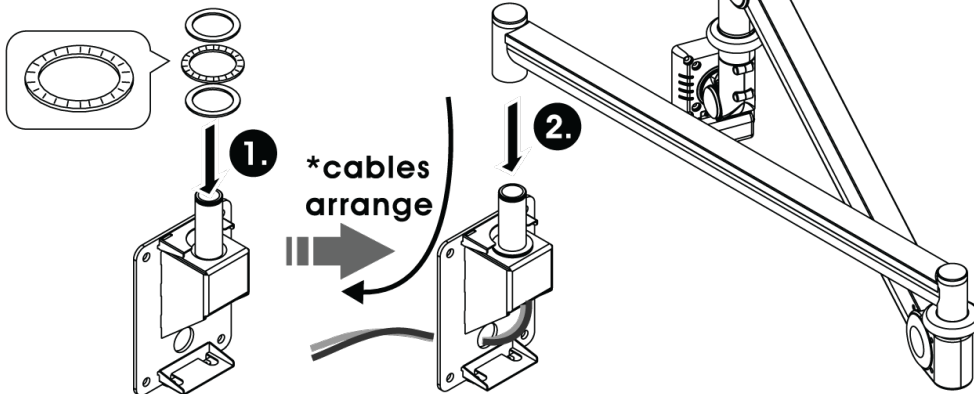



INSTRUCTION MANUAL

Note:

Note:

Please make sure this joint is in vertical 90 degree.

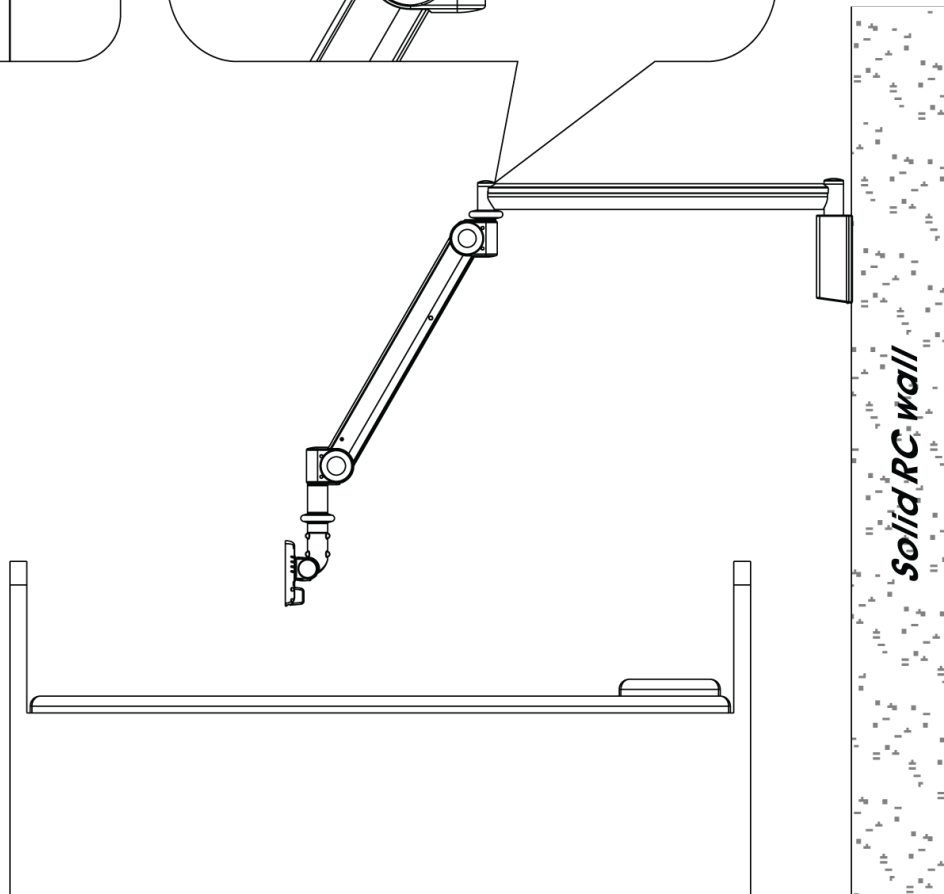
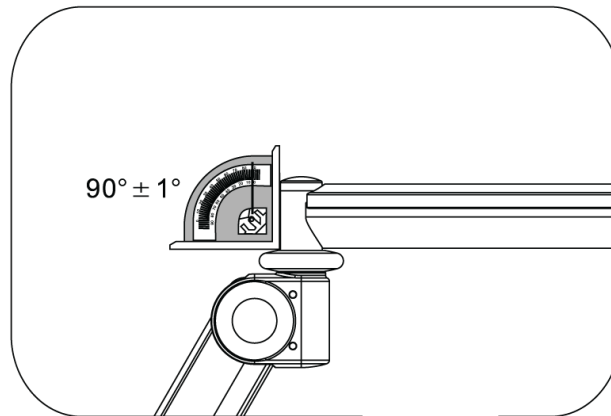
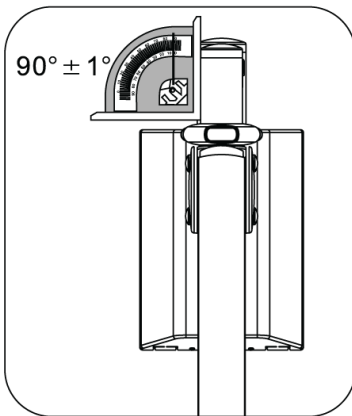

INSTRUCTION MANUAL

Cable assembly

Part introduction

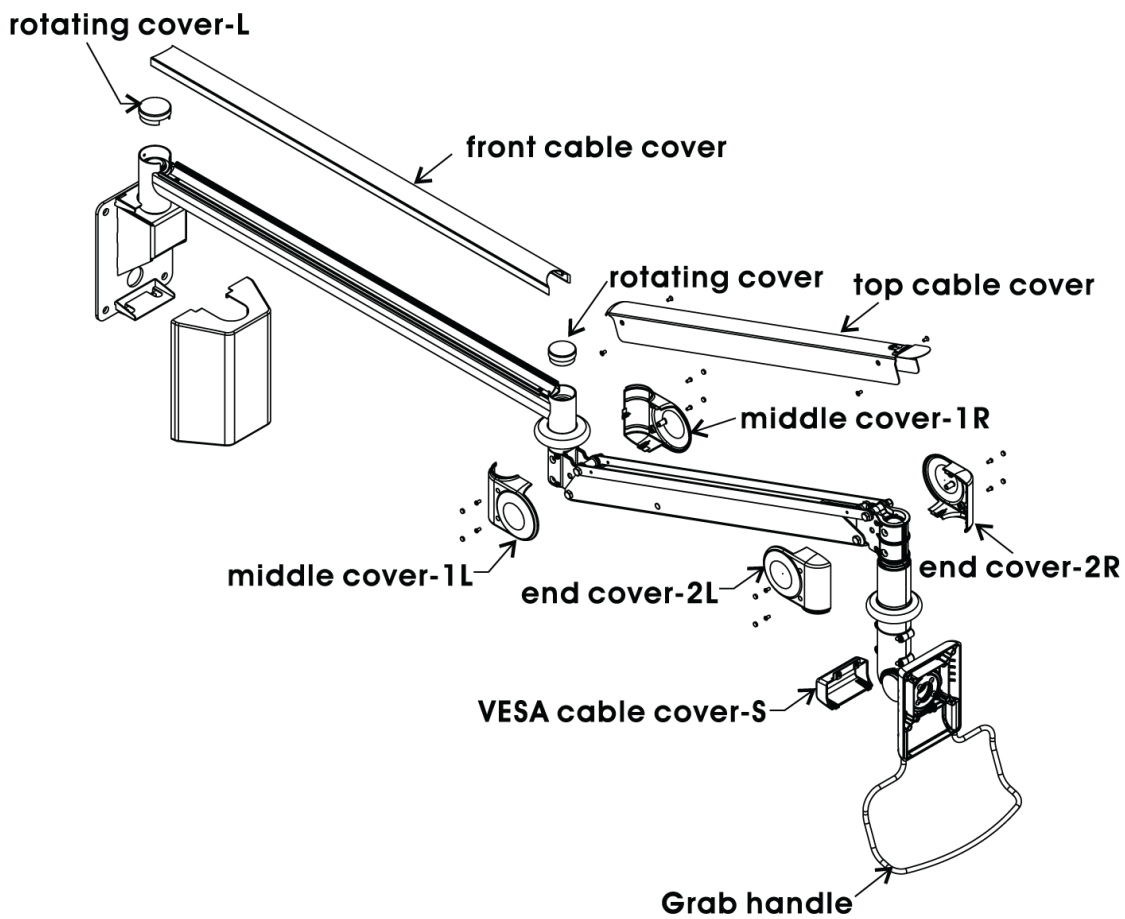

INSTRUCTION MANUAL

1.1 Remove cable covers :

Slid the cable cover out of the arm slot carefully as shown.

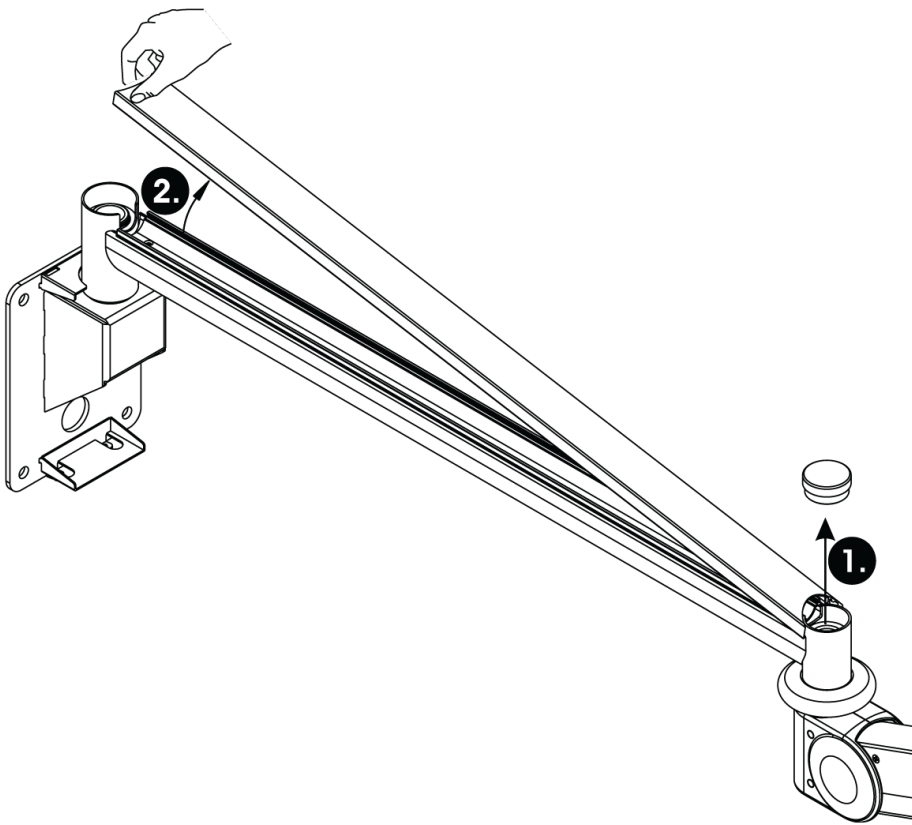



INSTRUCTION MANUAL

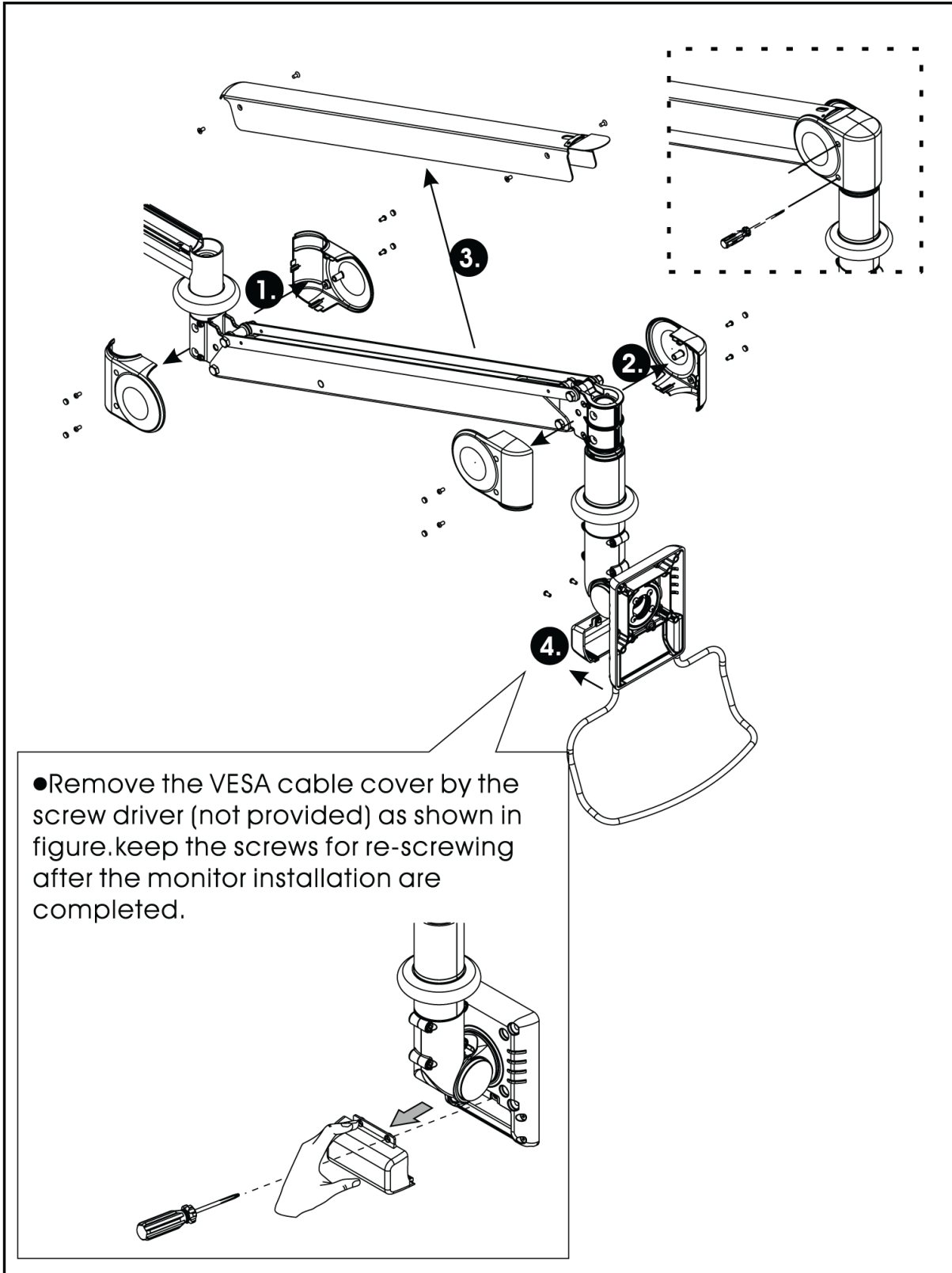

1.2 Remove cable covers :



INSTRUCTION MANUAL

1.3 Insert cables through arm

Cable Wrapper assembly

- ⑫  Cable Wrapper X1
- ⑬  Cable tie X4

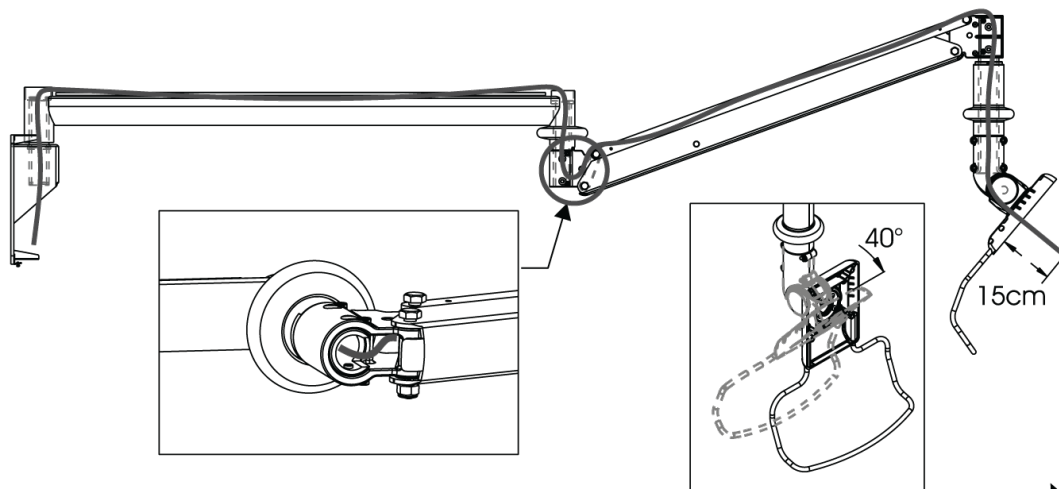
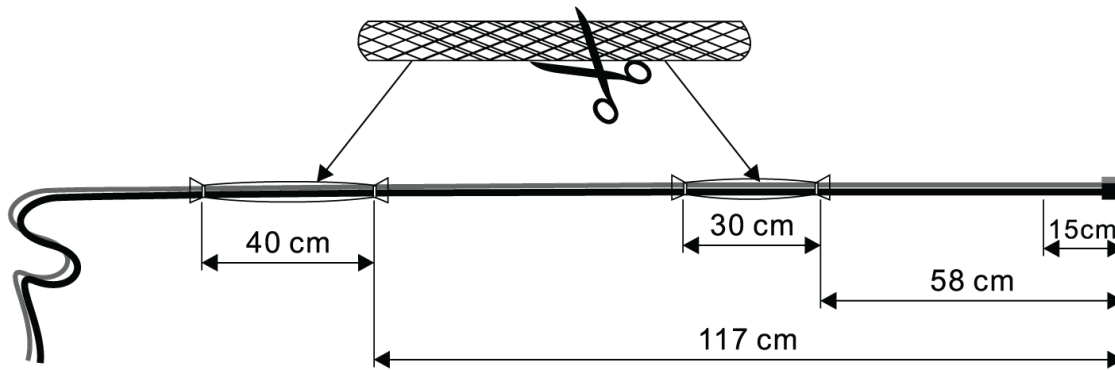

- The VESA adapter must be moved fully down for putting the cable through.
- Allowing for arm movement, we suggest leave at least 15 cm long cable from the VESA adapter as shown.





INSTRUCTION MANUAL

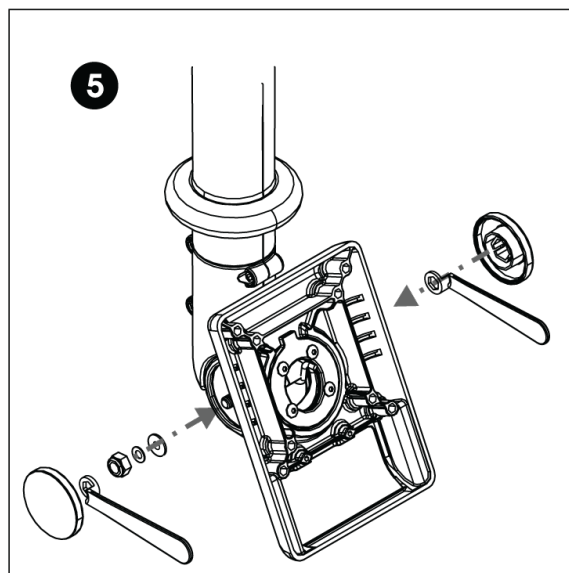
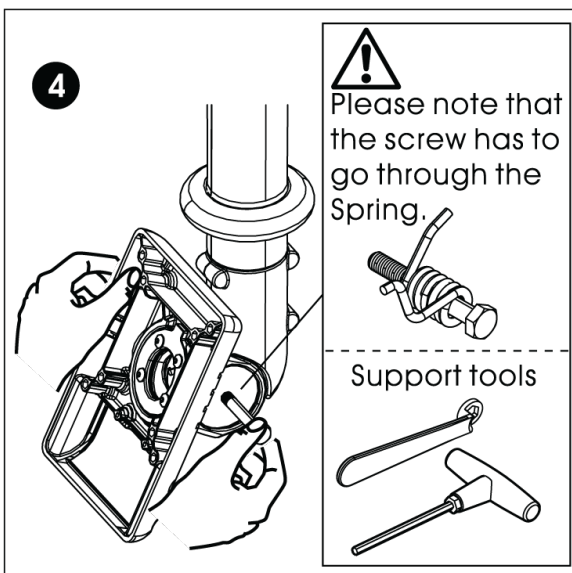
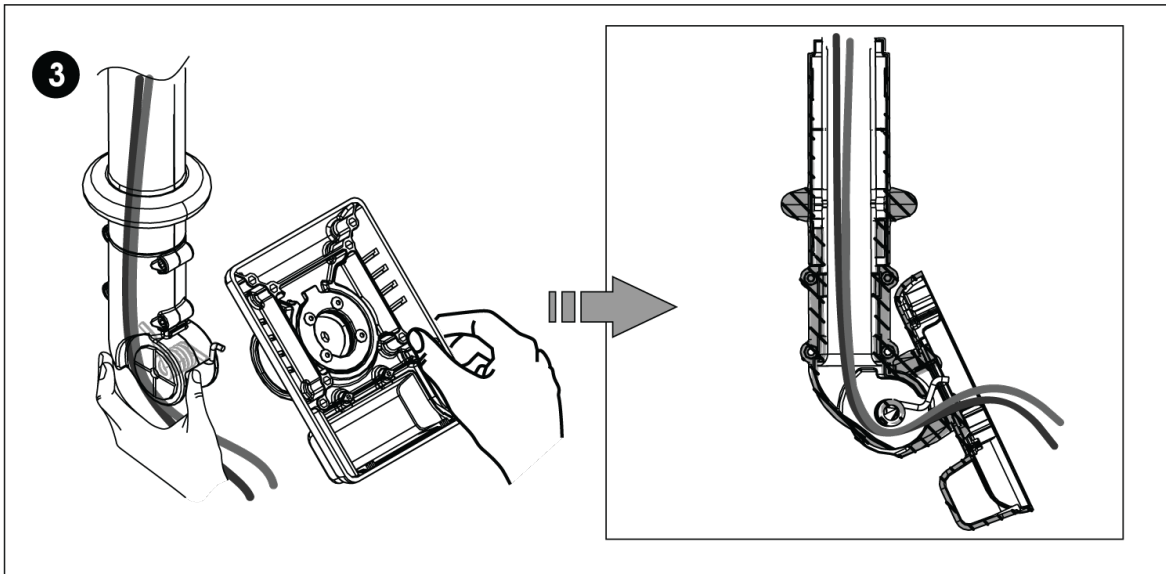
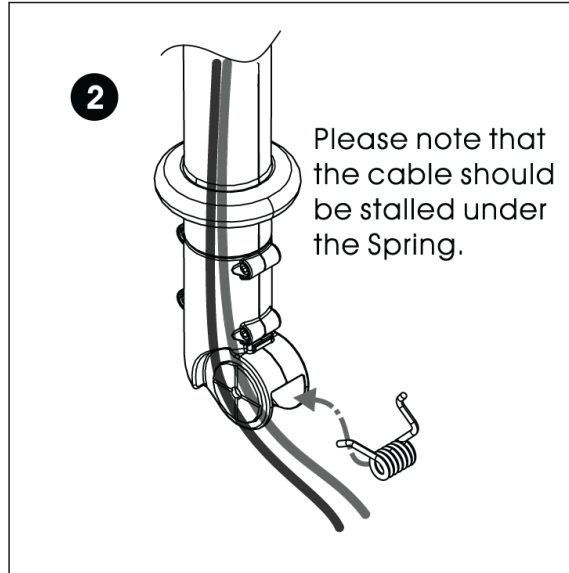
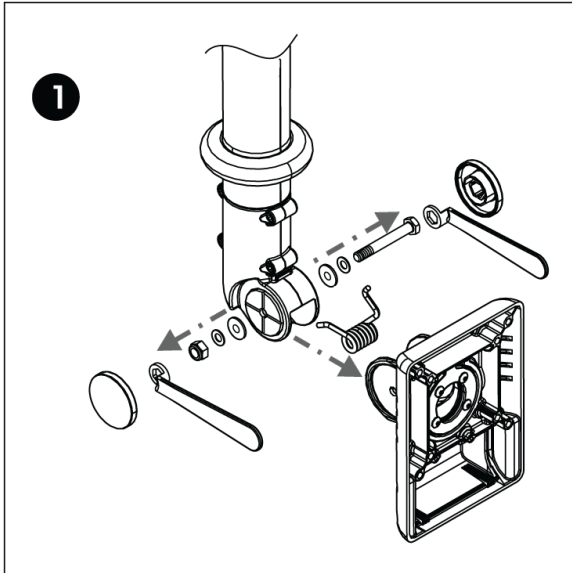

INSTRUCTION MANUAL

LCD Monitor Assembly

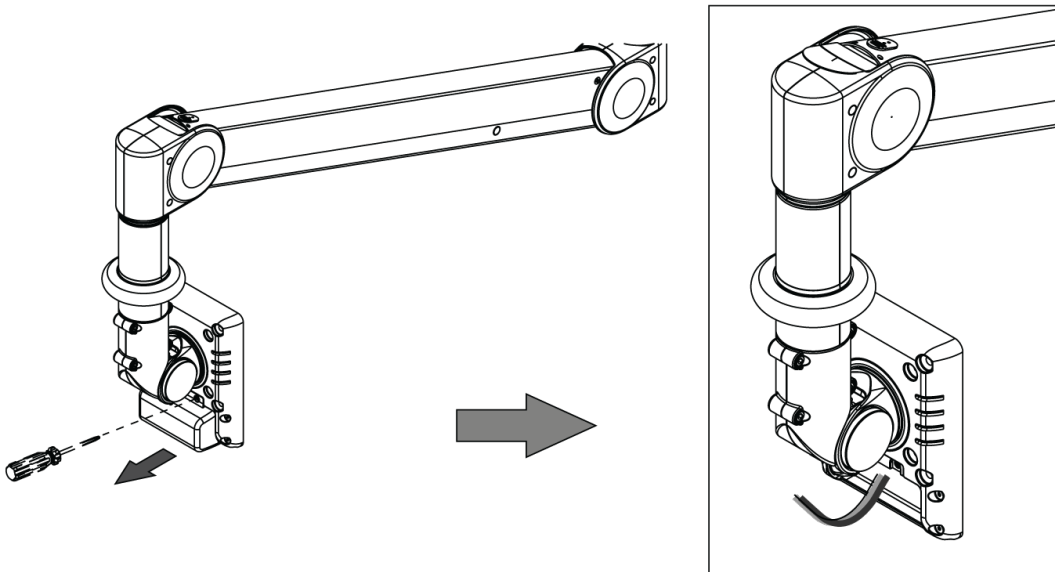

1.1

Please remove the back cap by the screw driver (not provided) as shown in figure. Please keep the screws in order to screw back after the monitor installation are completed. Then pull out the cable in order to install the monitor.





1.2

Fix the Monitor on the VESA mount using Allen Key and screws.

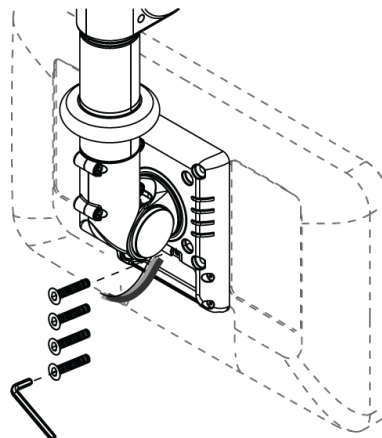
- 04  (M6X30) X4
- 08  (4mm) X1



- 05  (M4X25) X4
- 06  X4
- 07  (2.5mm) X1

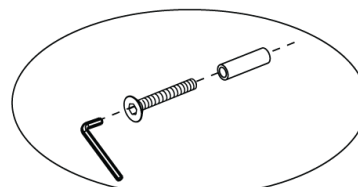
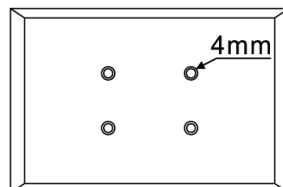

INSTRUCTION MANUAL

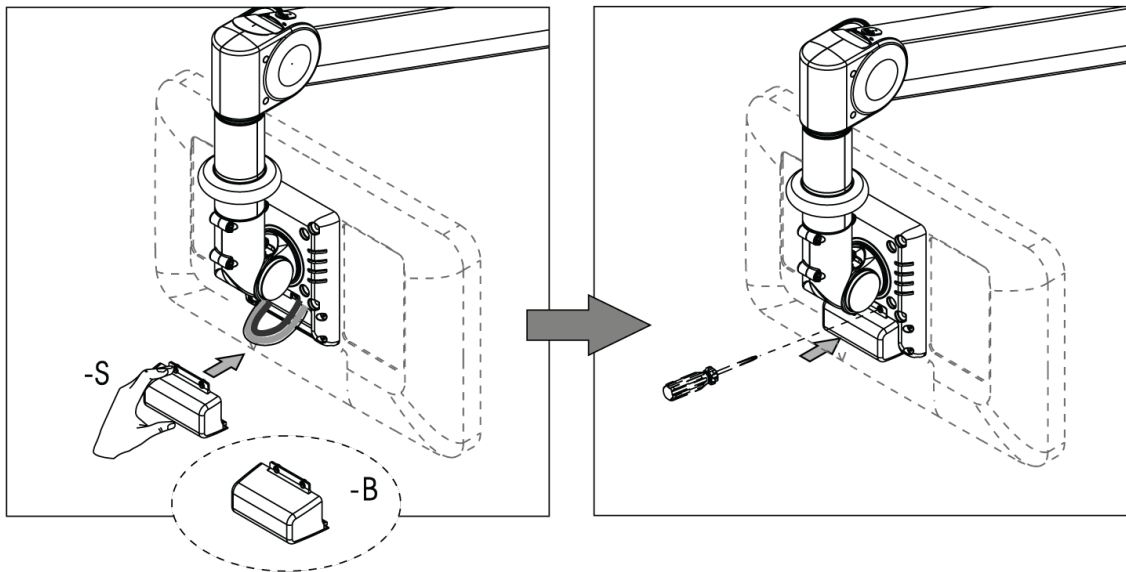

1.3 Connect cable to monitor

Connect the cables to the monitor, complete the circuit and then replace the VESA cable cover-B or VESA cable cover-S.



Fixing the Grab Handle

- Insert the grab handle into the 2 holes on the bottom of VESA interface.
- Then fix the grab handle with 4 screws by 2.5 mm Allen Key through the 4 holes on the lower part of VESA interface.

03		(M4X12) X4
07		(2.5mm) X1

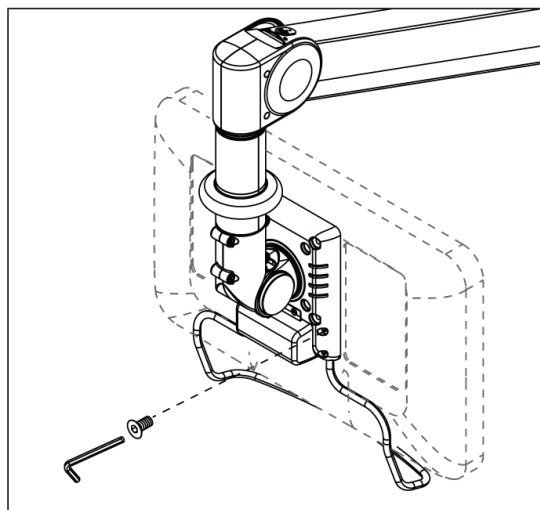

INSTRUCTION MANUAL

Adjustment For Loading

Caution for weight capacity adjustment:

1. Make sure you have checked out the weight of the panel you wish to mount.
2. Support the arm throughout/during assembly.

Adjustment:

Use the Allen key provided to adjust the weight capacity. Twist the Allen key in a clockwise direction for more weight; counterclockwise direction for less weight.

Loading:

WM 444.102: 1 - 6 Kg / WM 444.103: 6 - 12 Kg

- Products loading capacities are based on monitors' center of gravity less than 3cm from the end of the VESA interface.
- Loading capacity could be reduced if monitor size of greater than 26 inches or depth of greater than 5.5cm.
- All products specifications in catalogues are subject to change without notice.

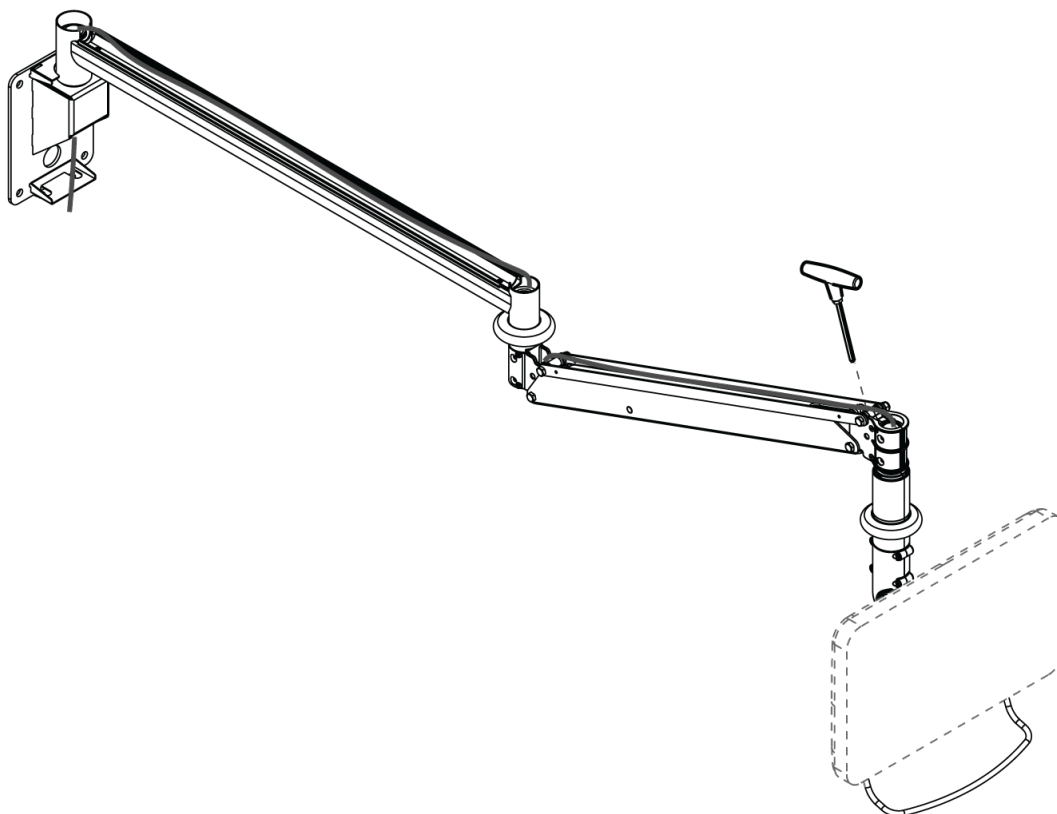



INSTRUCTION MANUAL

Replace the arm covers

1.1 Follow the order as below to assemble the covers.
Replace the adjuster covers as shown.

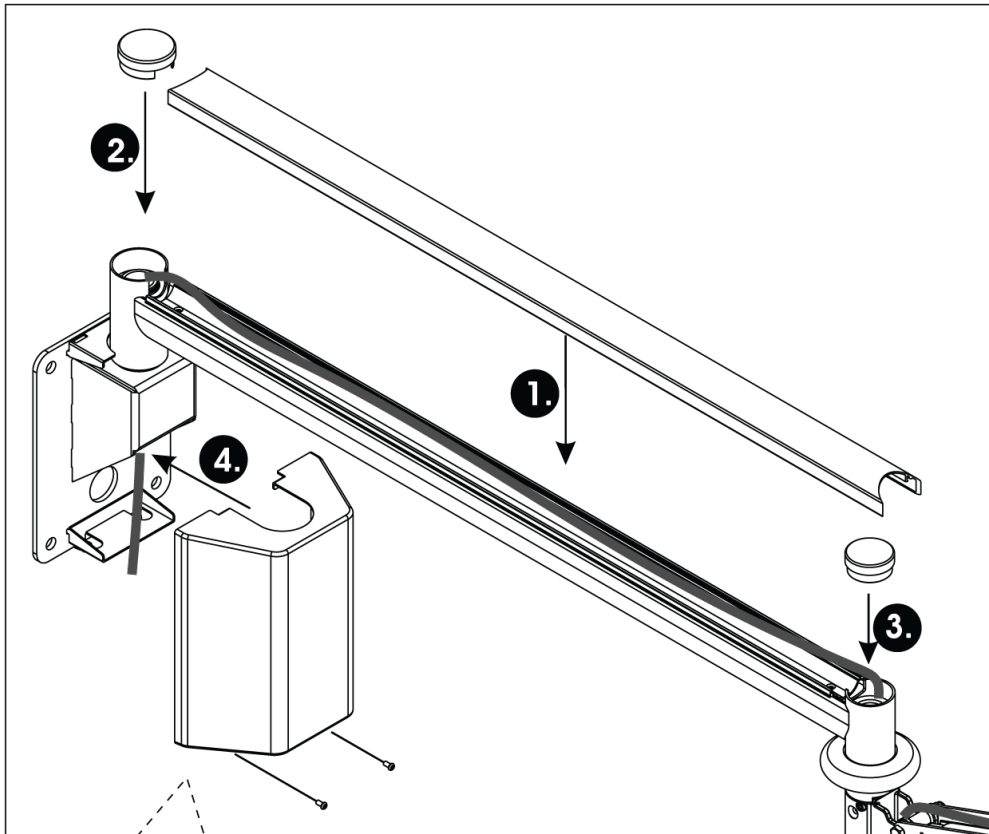

4.

- Cut off the flake on the bottom of the cover with the side-cutting pliers (not provided) to make a breach as figure for the cables to go through (if necessary).

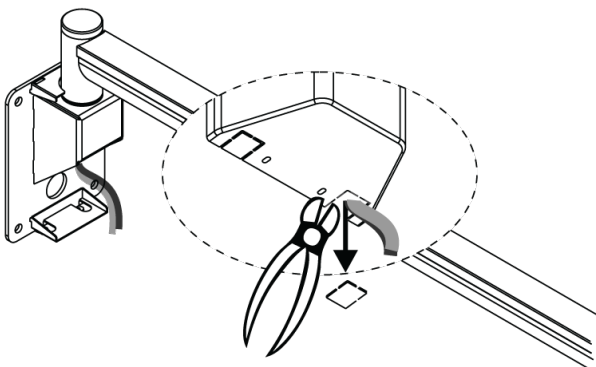

Fix the cover on the wall mount and screw the cover.

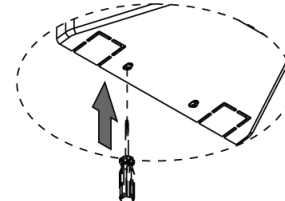
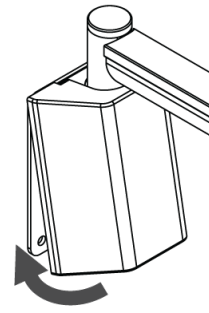
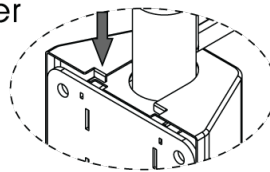



INSTRUCTION MANUAL

Replace the arm covers



1.2 Follow the order as below to assemble the covers.
Replace the adjuster covers as shown.

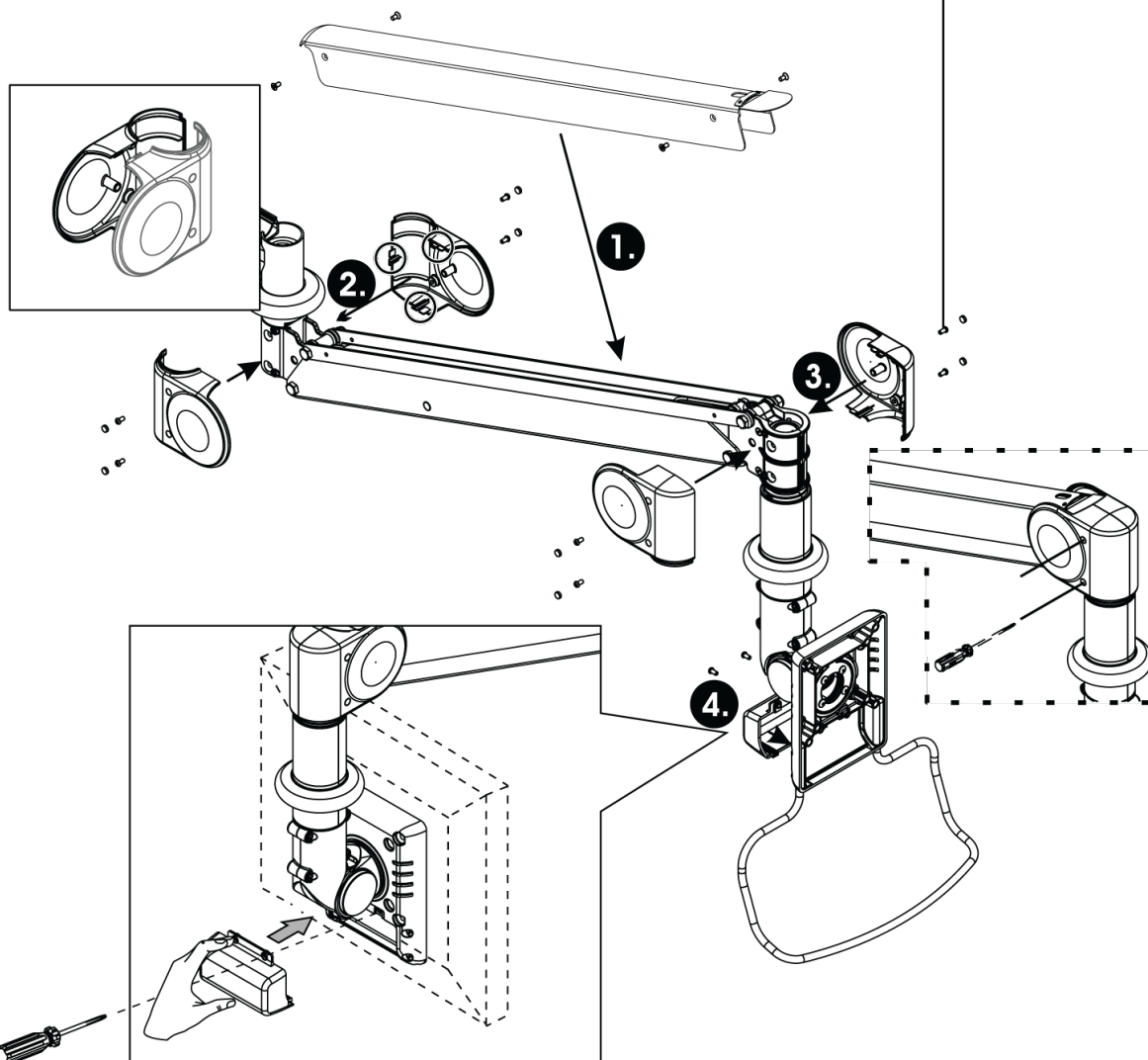
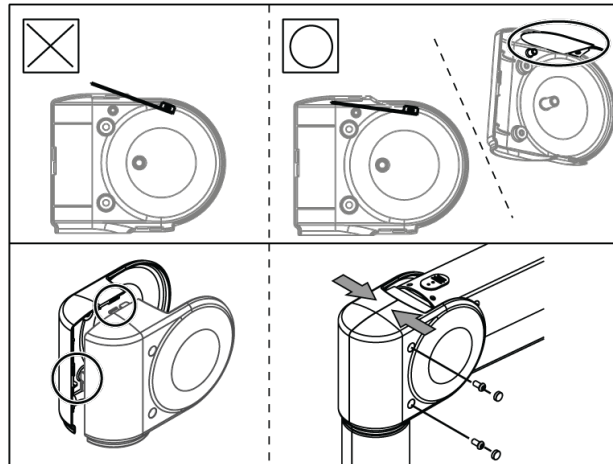



INSTRUCTION MANUAL

Adjustment For Loading

Caution for weight capacity adjustment:

1. Make sure you have checked out the weight of the panel you wish to mount.
2. Support the arm throughout/during assembly.
3. Pull down the arm and take out the upper cap (See as below figure) when adjust.

Adjustment:

Use the Allen key provided to adjust the weight capacity. Twist the Allen key in a clockwise direction for more weight; counterclockwise direction for less weight.

Loading

FPMA-HAW100 : 1~6 kg / FPMA-HAW100HC : 6~12 kg.

- Products loading capacities are based on monitors' center of gravity less than 3cm from the end of the VESA interface. Loading capacity could be reduced if monitor size of greater than 26 inches or depth of greater than 5.5cm.
- All products specifications in catalogues are subject to change without notice.

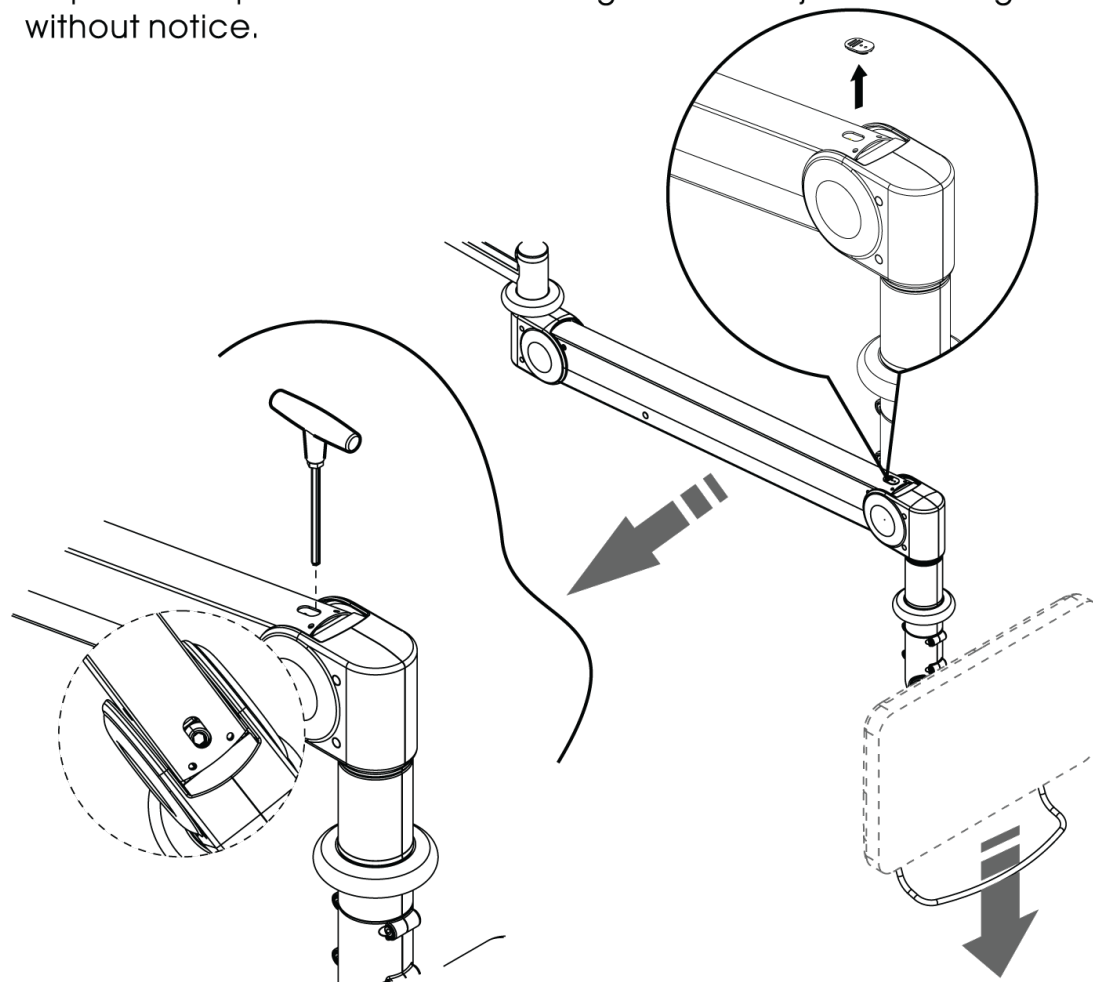

INSTRUCTION MANUAL

Adjusting Universal Joint Tension

When assembling the arm with monitors of different weights, you may find that the tension of the universal joint needs to be adjusted to ease movement or to maintain the desired monitor position. If so, adjust as follows:

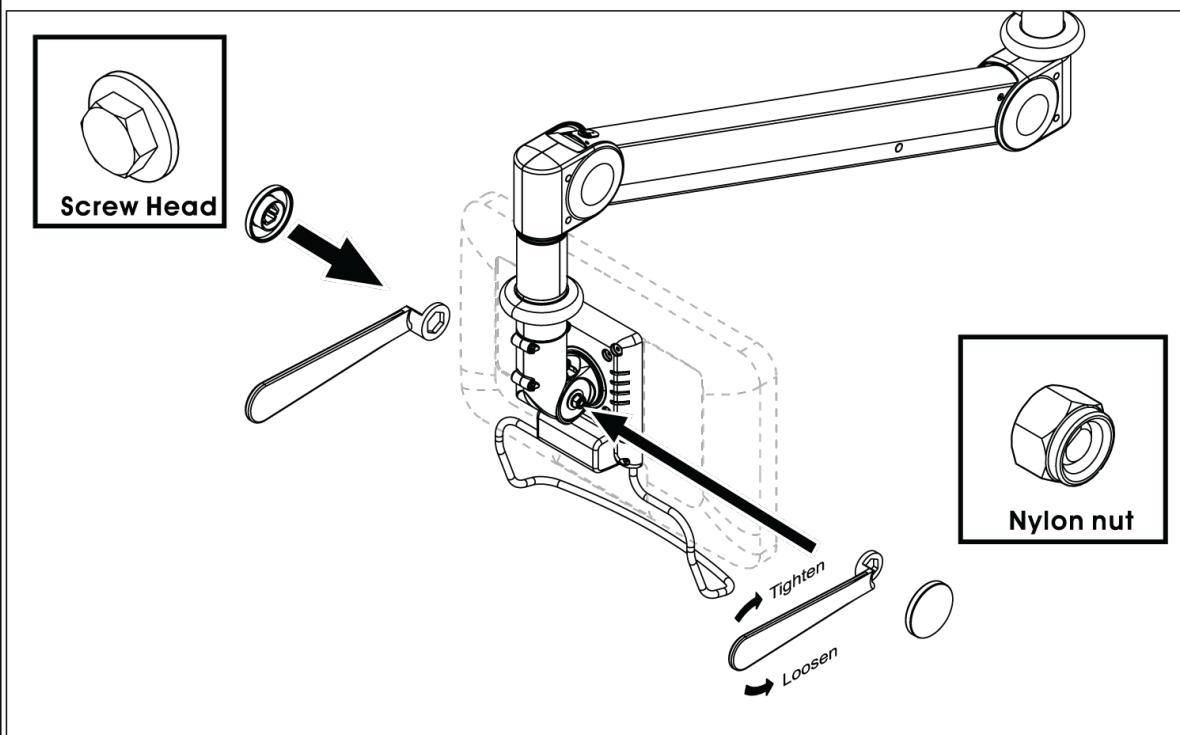

- Remove the plastic universal joint cover.
- Find the nylon nut (not the screw head) and use the provided wrench to adjust the tension . Fix the screw head by wrench at the same time when adjust.
- Use one hand to support the monitor and adjust the tension of the universal joint.
 - Clockwise : more tension
 - Counterclockwise : less tension
- When the desired tension is achieved, replace the plastic cover.

Caution:

- Support the monitor during the adjustment procedure.
- Only adjust the nylon nut (not the screw head).
- Do not disassemble the universal joint .



INSTRUCTION MANUAL

Safety Notes

- Once assembled DO NOT dis-assemble.
- Make sure that mounting screws are suitable for the vertical surface and adequate to hold the weight of the arm and the monitor.
- Support the monitor and arm throughout assembly and mounting.
- Keep small parts out of the reach of children.



- Make sure that the vertical surface is substantial to take the weight of the arm and monitor.

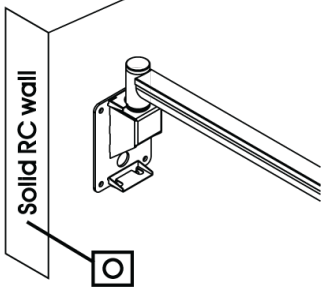

- Do Not Swing on Arm.

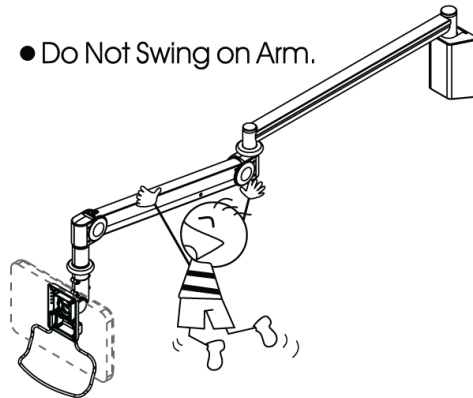

- Only use with LCD/TFT monitors that are VESA compliant- 75/75mm, 100/100mm.

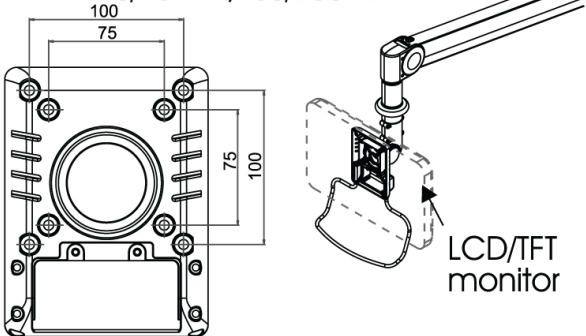

- Do not hold the arm as support to get up.

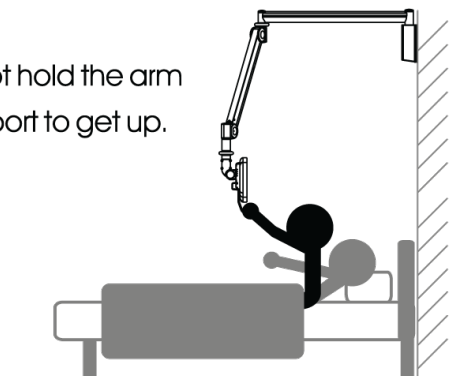

- Monitors to be mounted should not weigh any more than between.

max Loading:

FPMA-HAW100 : 1~6 kg

FPMA-HAW100HC : 6~12 kg.

- Products loading capacities are based on monitors' center of gravity less than 3cm from the end of the VESA interface. Loading capacity could be reduced if monitor size of greater than 26 inches or depth of greater than 5.5cm.
- All products specifications in catalogues are subject to change without notice.



- Do not hang unnecessary objects on the arm.

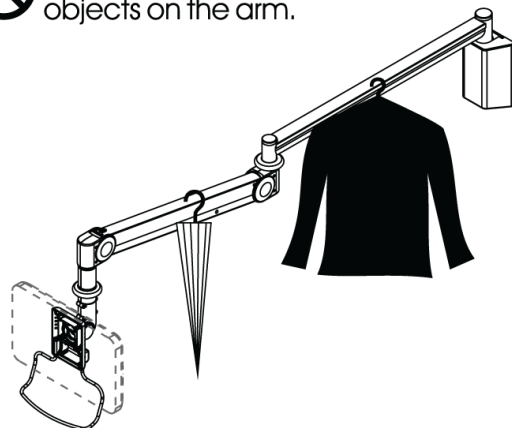

INSTRUCTION MANUAL

Cleaning Recommendations

- (1) Please use non-abrasive or diluted products to clean plastic components such as soap · water and diluted alcohol.
 - (2) If there are spots of pen or marker on the arm's surface, a soft cloth with 91% isopropyl alcohol is suggested for clean.
 - (3) If there are iodine spots on the arm's surface, a soft cloth with above cleansers is suggested for clean.
- ▲ The following chemicals are forbidden strictly cleaning the arm : Abrasive cleansers · Acetone · Mineral spirits · Paint thinner or any other harsh or toxic chemicals.



INSTRUCTION MANUAL

EN Caution

1. To ensure safety, please read this manual carefully before installation and follow the instructions. Store this manual in a secure place for future reference.
2. The manufacturer shall not be legally responsible for any equipment damage or personal injury caused by incorrect installation or operation other than that covered in this manual.
3. The mount is designed for easy installation and removal. The manufacturer shall not be liable for damage to equipment or personnel injuries arising out of human factors or acts of God, such as earthquake or typhoon.
4. It is recommended that the Wall mount bracket be installed by qualified personnel only.
5. At least two persons are needed to install or remove the product to avoid hazard of falling objects.
6. Please carefully inspect the area where the wall mount is to be installed:
 - Avoid places that are subject to high temperatures, humidity or contact with water.
 - Do not install the product near air conditioning vents or areas with excess dust and fumes.
 - Only install on vertical walls and avoid slanted surfaces.
 - Do not install in places subject to any shock or vibration.
 - Do not install in places subject to direct exposure to bright light, as it may cause eye fatigue when viewing the display panel.
7. Maintain sufficient space around the display to ensure adequate ventilation.
8. To ensure safe installation, first check the structure of the wall and select a secure mounting location.
9. The wall should be strong enough to sustain a weight of at least four times of the display and Wall mount bracket combined. The mounting location must be able to withstand earthquake or other strong shock.
10. Do not modify any accessories or use broken parts. Contact your dealer with any questions.
11. Tighten all screws (do not exert excessive force to avoid breaking the screw or damaging its thread).
12. Drill holes and bolts will be left in the wall once the display and Wall mount bracket are removed. Stains may occur after extended use.
13. Since the manufacturer has no way to control the wall type and installation of wall mount, the warranty of the product shall only cover the body of the wall mount. The warranty period of the product is 5 years.
14. Please consult the English language manual for any dispute on conditions.

FR Attention

1. Afin d'assurer votre sécurité, nous vous prions de bien lire le manuel avant l'installation et de suivre attentivement les instructions qui y sont incluses. Conservez ce manuel dans un endroit sûr comme référence.
2. Le fabricant ne sera tenu légalement responsable d'aucun dommage à l'équipement ou de blessure corporelle causés par une mauvaise installation ou utilisation de l'équipement autre que celle décrite au sein du présent manuel.
3. Le support de fixation murale est conçu de façon à faciliter l'installation et le déplacement. Le fabricant ne sera tenu responsable d'aucun dommage à l'équipement ou de blessure corporelle découlant d'erreur humaine ou de cas de force majeure, tels un tremblement de terre ou un typhon.
4. Il est recommandé de ne permettre qu'au personnel qualifié d'installer le support de fixation murale.
5. L'installation ou le déplacement du produit doit être accompli par un minimum de deux personnes afin d'éviter les dangers potentiels causés par une chute.
6. Nous vous prions d'inspecter soigneusement l'emplacement où le support de fixation murale sera installé:
 - N'installez pas le produit près de bouches d'air climatisé ou dans des endroits avec beaucoup de poussière ou de vapeurs toxiques.
 - N'installez pas le produit près de bouches d'air climatisé ou dans des endroits avec beaucoup de poussière ou de vapeurs toxiques.
 - N'installez que sur des murs verticaux et évitez les surfaces inclinées.
 - N'installez pas dans des endroits avec des chocs ou des vibrations.
 - N'installez pas dans des endroits exposés à des lumières fortes, cela pourrait causer la fatigue visuelle lors de l'observation du panneau d'affichage.
7. Laissez un espace suffisant autour de l'écran pour une ventilation adéquate.
8. Afin d'assurer la sécurité et la prévention des accidents, il est impératif de vérifier la structure du mur et de choisir un endroit solide avant de l'installer.
9. Le mur devrait être assez suffisamment fort pour soutenir un poids quatre fois supérieur à celui du poids combiné de l'écran et du support de fixation murale ensemble. L'emplacement du montage doit pouvoir survivre à un tremblement de terre ou autre choc intense.
10. No modifique ningún accesorio ni utilice componentes deteriorados. Póngase en contacto con su distribuidor si tiene alguna duda.
11. Resserrez toutes les vis (n'utilisez pas de force excessive pour éviter d'abîmer les vis ou le filetage).
12. Les trous de perçage et les écrous resteront dans le mur lorsque vous déplacerez l'écran et le support de fixation murale. Des taches peuvent apparaître après une longue utilisation.
13. Puisque le fabricant ne peut en aucun cas contrôler le type de mur et la qualité de l'installation du support de fixation murale, la garantie du produit ne couvre que le support de fixation murale. La durée de la garantie du

DE Vorsicht

1. Lesen Sie bitte vor der Installation das Handbuch sorgfältig durch und befolgen alle Anweisungen, um die Sicherheit zu gewährleisten. Heben Sie das Handbuch auf, damit Sie später darin nachlesen können.
2. Der Hersteller haftet für keine Geräte- oder Personenschäden, die durch unsachgemäße Installation oder Bedienung, die nicht in diesem Handbuch beschrieben ist, entstanden sind.
3. Die Wandmontage ist für eine einfache Installation und Demontage ausgelegt. Der Hersteller haftet nicht für Geräte- oder Personenschäden, die durch menschliche Faktoren oder höhere Gewalt wie z.B. Erdbeben oder Orkan entstanden sind.
4. Wir empfehlen Ihnen die Wandhalterung nur von einem qualifizierten Techniker installieren zu lassen.
5. Die Installation oder Demontage des Produkts muss von mindestens zwei Personen ausgeführt werden, um die Gefahr, dass Gegenstände herunterfallen, zu vermeiden.
6. Bitte überprüfen Sie sorgfältig die Stelle, wo das Wandmontageset installiert wird:
 - Vermeiden Sie Stellen mit hohen Temperaturen oder Feuchtigkeit bzw. Stellen, die mit Wasser in Kontakt kommen können.
 - Installieren Sie das Produkt nicht in der Nähe von Klimaanlageöffnungen oder an einer Stelle, wo es übermäßig Staub und Rauch gibt.
7. Halten Sie das Produkt nur an einer vertikalen Wand. Vermeiden Sie schräge Oberflächen.
8. Installieren Sie das Produkt nicht an einer Stelle, an denen es Erschütterungen oder Schwingungen ausgesetzt ist.
9. Installieren Sie das Produkt nicht an einer Stelle mit direkter Sonneneinstrahlung bzw. starkem Licht. Dies fördert beim Anschauen der Bildschirmanzeige das Ermüden der Augen.
10. Modifizieren Sie keine Zubehöerteile. Verwenden Sie keine beschädigten Teile. Wenden Sie sich an Ihren Händler, wenn Sie Fragen haben.
11. Ziehen Sie alle Schrauben fest. (Wenden Sie nicht zu viel Kraft an, um ein Brechen der Schraube oder Beschädigen des Gewindes zu vermeiden.)
12. Die Bohrungen und die Schrauben bleiben an der Wand sichtbar, wenn das Anzeigegerät und das Wandmontageset entfernt wird. Nach längerem Gebrauch kann ein Fleck an der Wand bleiben.
13. Der Hersteller hat keinen Einfluss auf den Wandtyp und die Installation des Wandmontagesets. Deshalb deckt die Garantie des Produkts nur das Wandmontageset selbst ab. Die Garantie des Produkts gilt für 5 Jahre.
14. Bitte ziehen Sie die englische Version des Handbuchs zur Rate, falls es Unstimmigkeiten hinsichtlich der Bedingungen gibt.

ES Precaución

1. Para garantizar su seguridad, lea este manual detenidamente antes de la instalación y siga sus instrucciones. Conserve este manual en un lugar seguro para futuras consultas.
2. El fabricante no será legalmente responsable de ningún daño producido sobre el equipo o lesión personal causada por una instalación o uso no mencionado explícitamente en este manual.
3. El soporte de pared ha sido diseñado para instalar y retirar fácilmente el dispositivo. El fabricante no se hace responsable de los daños provocados sobre el equipo o las lesiones personales que se deriven de factores humanos o actos de fuerza mayor, como un terremoto o un tifón.
4. Se recomienda que el soporte de pared sea instalado por personal cualificado.
5. Para evitar que se caiga el producto, la instalación o retirada deberá ser realizada por al menos dos personas.
6. Inspeccione detenidamente el área en el que desea instalar el soporte de pared:
 - Evite los lugares sometidos a altas temperaturas, alto nivel de humedad, o que se encuentren en contacto con el agua.
 - No instale el producto cerca de un orificio de aire acondicionado, o en zonas con gran cantidad de polvo o humos.
 - Instale el producto en una pared vertical. Evite las superficies sesgadas.
 - No instale el producto en lugares sujetos a golpes o vibraciones.
7. Mantenga espacio libre suficiente alrededor de la pantalla para asegurar su adecuada ventilación.
8. Para garantizar su seguridad y evitar accidentes, compruebe la estructura de la pared y seleccione un emplazamiento seguro antes de la instalación.
9. La pared debe tener fuerza suficiente para soportar un peso de al menos cuatro veces la pantalla y el soporte en conjunto. El lugar de montaje debe ser capaz de aguantar terremotos u otros golpes fuertes.
10. No modifique ningún accesorio ni utilice componentes deteriorados. Póngase en contacto con su distribuidor si tiene alguna duda.
11. Apriete todos los tornillos (no ejerza demasiada fuerza para evitar que se roma el tornillo o se dañe la rosca).
12. Mantenga los orificios y los pernos en la pared después de retirar la pantalla y el soporte de pared. Podrían quedar manchas después de un uso prolongado.
13. Dado que el fabricante no dispone de ningún método para comprobar el tipo de pared e instalación del soporte, la garantía del producto cubre únicamente el soporte de pared en sí. El periodo de garantía de este producto es de 5 años.
14. Consulte el manual en inglés si tiene alguna duda acerca de las condiciones.

IT Attenzione

1. Per garantire la sicurezza, leggere attentamente questo manuale prima di effettuare l'installazione e seguire le istruzioni qui contenute. Conservare questo manuale in un luogo sicuro per riferimenti futuri.
2. Il produttore non deve essere ritenuto responsabile legalmente per qualsiasi danno all'apparecchio o lesione alla persona provocati da installazione non corretta o funzionamento diverso da quello riportato nel seguente manuale.
3. Il montaggio a parete è stato ideato per una facile installazione e rimozione. Il produttore non sarà responsabile per danni all'apparecchio o per lesioni alla persona derivanti da fattori umani o eventi naturali, come tifoni o terremoti.
4. Si consiglia di far installare la staffa per il montaggio a parete solo da personale qualificato.
5. Per installare o rimuovere il prodotto sono necessarie almeno due persone per evitare rischi di caduta di oggetti.
6. Controllare attentamente l'area dove va effettuato il montaggio:
 - Evitare luoghi soggetti a temperature alte, umidità o contatto con l'acqua.
 - Non installare il prodotto accanto a uscite di ventilazione di aria condizionata o aree con polvere o fumi eccessivi.
 - Installare solo su pareti verticali, evitare superfici inclinate.
 - Non installare in luoghi soggetti a urti o vibrazioni.
 - Non installare in luoghi soggetti a esposizione diretta alla luce, in quanto si potrebbe provocare affaticamento agli occhi durante la visualizzazione del pannello.
7. Mantenere spazio sufficiente intorno al monitor per garantire una adeguata ventilazione.
8. Per garantire la sicurezza e per prevenire incidenti, è necessario, prima di eseguire l'installazione, controllare la struttura della parete e scegliere un posizionamento sicuro.
9. La parete deve essere abbastanza forte per sostenere almeno quattro volte il peso del monitor e della staffa per il montaggio insieme. Il punto di montaggio deve essere in grado di sopportare terremoti o urti forti.
10. Non modificare gli accessori o utilizzare parti rotte. Contattare il rivenditore per qualsiasi domanda.
11. Stringere tutte le viti (non applicare forza eccessiva per evitare la rottura delle viti o il danneggiamento della filettatura).
12. Fori e bulloni possono essere lasciati sulla parete una volta rimossi la staffa e il monitor. Dopo un periodo prolungato di utilizzo, possono formarsi delle macchie.
13. Dato che il produttore non ha alcun modo di controllare il tipo di parete e l'installazione, la garanzia del prodotto coprirà esclusivamente il corpo della struttura per il montaggio. Il periodo di garanzia del prodotto è di 5 anni.
14. Consultare il manuale in lingua inglese per eventuali controversie sulle condizioni.